

# HepcoMotion®

## HLG

### Hepco Linear Ball Guides

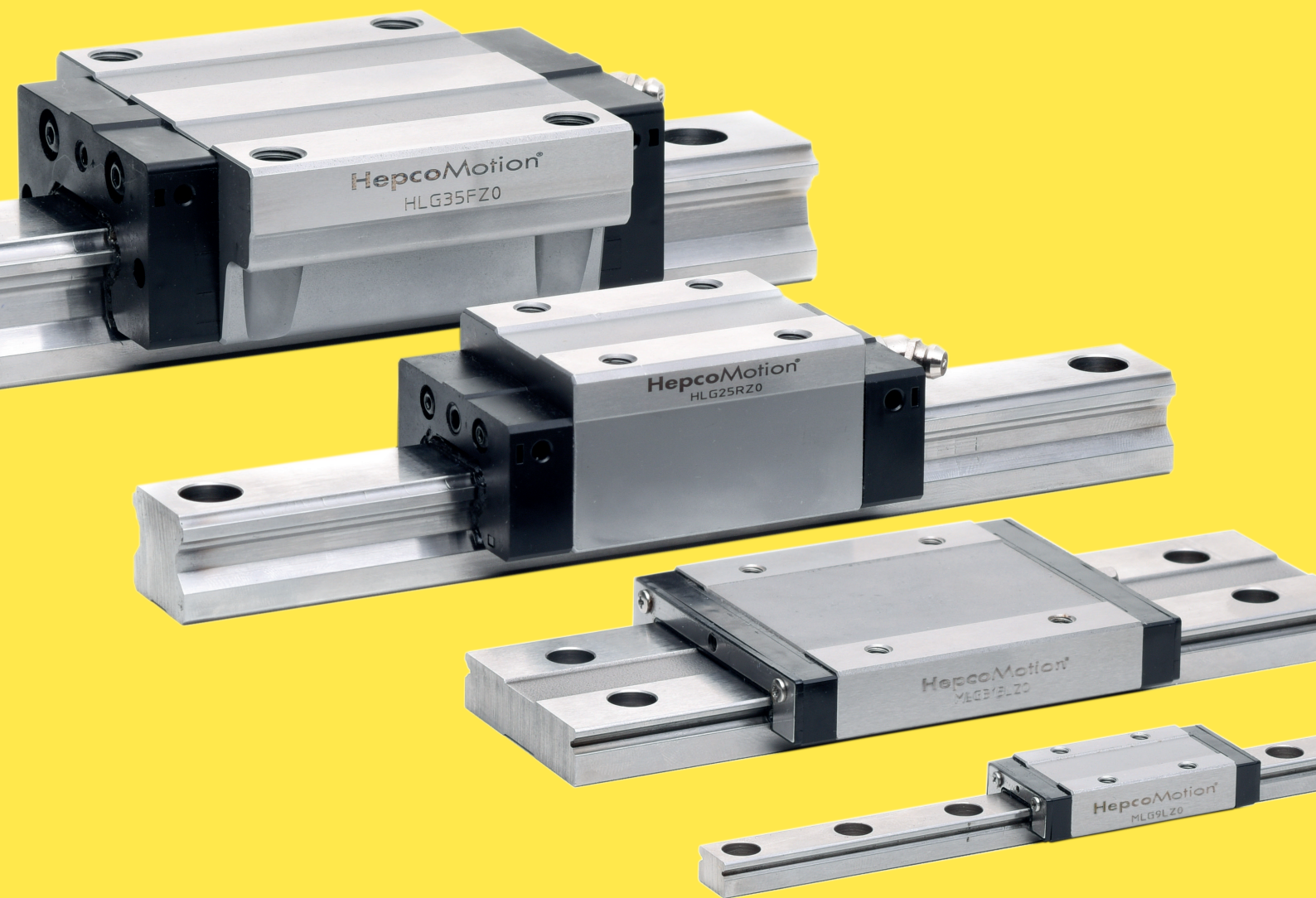

[www.HepcoMotion.com](http://www.HepcoMotion.com)

## Contents

<b>Introduction</b> .....	<b>1</b>
<b>Comparison Table</b> .....	<b>2</b>
<b>Block Mounting and Rail Mounting Options</b> .....	<b>3</b>
<b>Rail Lengths (Standard)</b> .....	<b>4</b>
<b>HLG Product Pages</b>	
<b>Linear Motion Guide: HLG--F</b> .....	<b>5</b>
<b>HLG--FL</b> .....	<b>5</b>
<b>HLG--R</b> .....	<b>6</b>
<b>HLG--RL</b> .....	<b>6</b>
<b>Slim Linear Motion Guide: HLGS--C</b> .....	
<b>HLGS--R</b> .....	<b>7</b>
<b>HLGS--CF</b> .....	<b>8</b>
<b>HLGS--F</b> .....	<b>8</b>
<b>MLG/MLGB Miniature Range</b>	
<b>Miniature Linear Motion Guide: MLG-C</b> .....	<b>11</b>
<b>MLG-N</b> .....	<b>11</b>
<b>MLG-L</b> .....	<b>11</b>
<b>Miniature Wide Linear Motion Guide: MLGB-C</b> .....	<b>12</b>
<b>MLGB-N</b> .....	<b>12</b>
<b>MLGB-L</b> .....	<b>12</b>
<b>HLG Brake</b> .....	<b>13-16</b>
<b>Life Calculations</b> .....	<b>17</b>
<b>Pre-Load &amp; Rigidity</b> .....	<b>18</b>
<b>Seal Resistance</b> .....	<b>18</b>
<b>Precision/Accuracy Data</b> .....	<b>19-21</b>
<b>Surface Treatment</b> .....	<b>20</b>
<b>Lubrication</b> .....	<b>22</b>
<b>Sealing</b> .....	<b>23</b>
<b>Installation Data</b> .....	<b>24-26</b>
<b>Ordering Detail</b> .....	<b>27</b>

## HLG HepcoMotion Linear Guides

The **HLG** range of recirculating ball guides brings a new dimension to linear motion by offering smooth low friction movement, high rigidity and an excellent load capacity, all at prices that will reduce your installed machine cost.

The range is available in standard sizes and offers the unique bleed lubrication system that enables blocks to be re-greased through the rail, making it easy to set up an automatic lubrication facility.

Blocks have a highly effective sealing arrangement at both ends and along the sides. This prevents serious dirt ingress and enables grease to be retained, where it matters, to lubricate the internal tracks.

For manual applications there is the option of a fitted brake that enables blocks to be firmly locked in position.

The **HLG** range also includes a miniature series, **MLG**, in standard and wide block versions. These high precision units also include the brake option facility. Manufactured as standard in stainless steel, **MLG** will be an ideal match for any scientific or medical application or installations where space is limited.

Available across all precision grades and preloads, **HLG** will provide you with a durable, high performance linear guide solution.

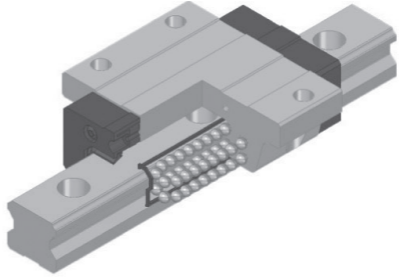
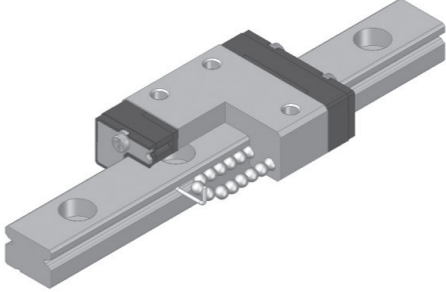
Range		Features
<b>HLG</b> Standard Linear Motion Guide		<ul style="list-style-type: none"> <li>- International standard</li> <li>- Four directional equal load type</li> <li>- 40° contact angle</li> <li>- Good error absorbing ability</li> <li>- High rigidity</li> </ul>
<b>MLG/MLGB</b> Miniature Linear Motion Guide		<ul style="list-style-type: none"> <li>- Miniature versions in compact or wide type, each with three block options</li> <li>- Stainless steel construction</li> <li>- Compact design</li> <li>- High load carrying capacity</li> </ul>

## Comparison Table of HLG Linear Ball Guides and those of Other Manufacturers

Hepco	THK	NSK	PMI	HIWIN
<b>HLG15F</b> <b>HLG15FL</b>	HSR15A, B	LH15EL, EM LH15GL, GM	MSA15A	HGW15CA
<b>HLG20F</b> <b>HLG20FL</b>	HSR20A, B HSR20LA, LB	LH20EL, EM LH20GL, GM	MSA20A MSA20LA	HGW20CA HGW20HA
<b>HLG25F</b> <b>HLG25FL</b>	HSR25A, B HSR25LA, LB	LH25EL, EM LH25GL, GM	MSA25A MSA25LA	HGW25CA HGW25HA
<b>HLG30F</b> <b>HLG30FL</b>	HSR30A, B HSR30LA, LB	LH30EL, EM LH30GL, GM	MSA30A MSA30LA	HGW30CA HGW30HA
<b>HLG35F</b> <b>HLG35FL</b>	HSR35A, B HSR35LA, LB	LH35EL, EM LH35GL, GM	MSA35A MSA35LA	HGW35CA HGW35HA
<b>HLG45F</b> <b>HLG45FL</b>	HSR45A, B HSR45LA, LB	LH45EL, EM LH45GL, GM	MSA45A MSA45LA	HGW45CA HGW45HA
<b>HLG55F</b> <b>HLG55FL</b>	HSR55A, B HSR55LA, LB	LH55EL, EM LH55GL, GM	MSA55A MSA55LA	HGW55CA HGW55HA

<b>HLG15R</b> <b>HLG15RL</b>	HSR15R	LH20AN, AL LH15BN, BL	MSA15S	HGH15CA
<b>HLG20R</b> <b>HLG20RL</b>	HSR20R HSR20LR	LH20AN, AL LH20BN, BL	MSA20S MSA20LS	HGH20CA HGH20HA
<b>HLG25R</b> <b>HLG25RL</b>	HSR25R HSR25LR	LH25AN, AL LH25BN, BL	MSA25S MSA25LS	HGH25CA HGH25HA
<b>HLG30R</b> <b>HLG30RL</b>	HSR30R HSR30LR	LH30AN, AL LH30BN, BL	MSA30S MSA30LS	HGH30CA HGH30HA
<b>HLG35R</b> <b>HLG35RL</b>	HSR35R HSR35LR	LH35AN, AL LH35BN, BL	MSA35S MSA35LS	HGH35CA HGH35HA
<b>HLG45R</b> <b>HLG45RL</b>	HSR45R HSR45LR	LH45AN, AL LH45BN, BL	MSA45S MSA45LS	HGH45CA HGH45HA
<b>HLG55R</b> <b>HLG55RL</b>	HSR55R HSR55LR	LH55AN, AL LH55BN, BL	MSA55S MSA55LS	HGH55CA HGH55HA

<b>HLGS15C</b> <b>HLGS15R</b>	SR15V SR15W	LS15CL LS15AL	MSB15TS MSB15S	EGH15SA EGH15CA
<b>HLGS20C</b> <b>HLGS20R</b>	SR20V SR20W	LS20CL LS20AL	MSB20TS MSB20S	EGH20SA EGH20CA
<b>HLGS25C</b> <b>HLGS25R</b>	SR25V SR25W	LS25CL LS25AL	MSB25TS MSB25S	EGH25SA EGH25CA

<b>HLGS15CF</b> <b>HLGS15F</b>	SR15SB SR15TB	LS15EM LS15JM	MSB15TE MSB15E	EGW15CA EGW15CB
<b>HLGS20CF</b> <b>HLGS20F</b>	SR20SB SR20TB	LS20EM LS20JM	MSB20TE MSB20E	EGW20CA EGW20CB
<b>HLGS25CF</b> <b>HLGS25F</b>	SR25SB SR25TB	LS25EM LS25JM	MSB25TE MSB25E	EGW25CA EGW25CB

## HLG Type Block Mounting Options

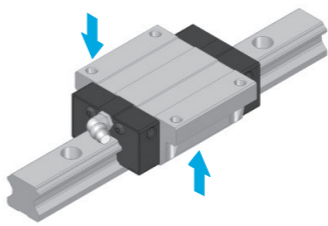
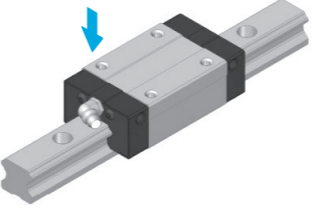
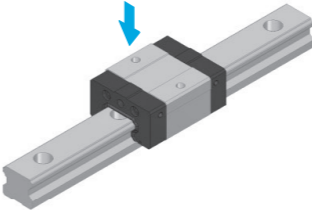
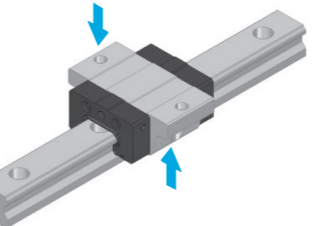
	<b>HLGF, HLGFL</b> Tapped hole in flange for mounting from above. Use bolt one size smaller when mounting from below.
	<b>HLGR, HGLRL</b> Tapped hole for mounting from above.
	<b>HLGSC, HGLSR</b> Tapped hole for mounting from above.
	<b>HLGSCF, HGLSF</b> Tapped hole in flange for mounting from above. Use bolt one size smaller when mounting from below.

## Linear Motion Guide Rail Mounting Options

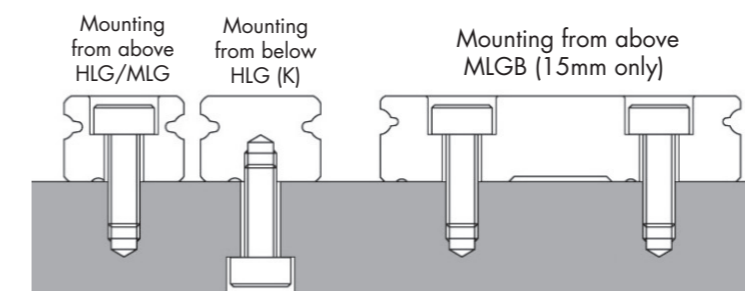

See page 27 for ordering details.

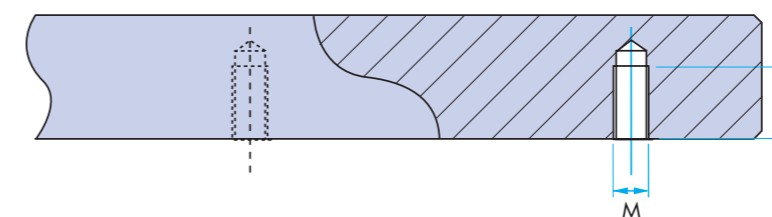

Mounting from below (K)

Part No.	M x L
<b>HLG15K</b>	M5 x 8
<b>HLG20K</b>	M6 x 10
<b>HLG25K</b>	M6 x 12
<b>HLG30K</b>	M8 x 15
<b>HLG35K</b>	M8 x 17
<b>HLG45K</b>	M12 x 24
<b>HLG55K</b>	M14 x 19

## HLG Standard Rail, Cut Length

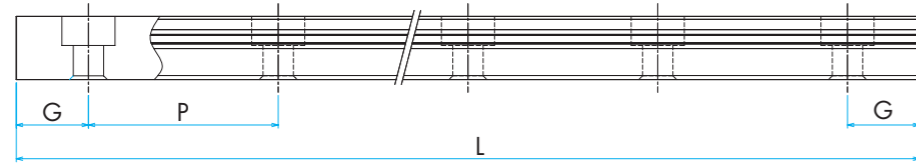

Standard Rail Lengths L	Nominal Rail Size						
	15	20	25	30	35	45	55
	G =						
100	20	20	20	-	-	-	-
200	10	10	10	20	20	47.5	40
300	30	30	30	30	30	45	30
400	20	20	20	40	40	42.5	20
500	10	10	10	50	50	40	70
600	30	30	30	20	20	37.5	60
700	20	20	20	30	30	35	50
800	10	10	10	40	40	32.5	40
900	30	30	30	50	50	30	30
1000	20	20	20	20	20	27.5	20
1100	10	10	10	30	30	25	70
1200	30	30	30	40	40	22.5	60
1300	20	20	20	50	50	20	50
1400	10	10	10	20	20	17.5	40
1500	30	30	30	30	30	67.5	30
1600	20	20	20	40	40	65	20
1700	10	10	10	50	50	62.5	70
1800	30	30	30	20	20	60	60
1900	20	20	20	30	30	57.5	50
2000	10	10	10	40	40	55	40
2100	30	30	30	50	50	52.5	30
2200	20	20	20	20	20	50	20
2300	10	10	10	30	30	47.5	70
2400	30	30	30	40	40	45	60
2500	20	20	20	50	50	42.5	50
2600	10	10	10	20	20	40	40
2700	30	30	30	30	30	37.5	30
2800	20	20	20	40	40	35	20
2900	10	10	10	50	50	32.5	70
3000	30	30	30	20	20	30	60
3100	20	20	20	30	30	27.5	50
3200	10	10	10	40	40	25	40
3300	30	30	30	50	50	22.5	30
3400	20	20	20	20	20	20	20
3500	10	10	10	30	30	17.5	70
3600	30	30	30	40	40	67.5	60
3700	20	20	20	50	50	65	50
3800	10	10	10	20	20	62.5	40
3900	30	30	30	30	30	60	30

Hole pitch P	60	60	60	80	80	105	120
--------------	----	----	----	----	----	-----	-----

'G' is equal both ends unless requested otherwise. Non standard rail lengths are available.

For miniature rails **MLG/MLGB** please see page 11/12.

## HLG--F Series, HLG--FL Series

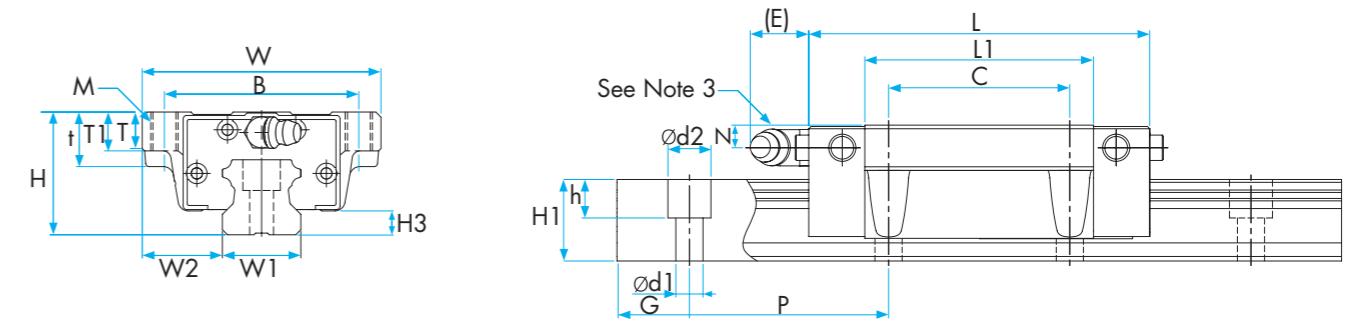

Ref No.	External Dimensions			Dimensions of HLG Block										H3
	Height H	Width W	Length L	B	C	M	L1	t	T	T1	N	E	Grease Nipple*3	
HLG15F	24	47	57	38	30	M5	40.8	-	7	11	6	6	A-M4	4.7
HLG15FL			65.3				49.1	-						
HLG20F	30	63	72.7	53	40	M6	53.1	-	9.2	10	7.5	12	B-M6F	6
HLG20FL			88.6				69	-						
HLG25F	36	70	83	57	45	M8	58.3	-	11.5	16	9	12	B-M6F	7
HLG25FL			102.9				78.2	-						
HLG30F	42	90	97.8	72	52	M10	70.8	-	9.5	18	7.3	12	B-M6F	7.5
HLG30FL			120				93	-						
HLG35F	48	100	110	82	62	M10	80.8	-	12.5	21	8	12	B-M6F	9
HLG35FL			135.4				106.2	-						
HLG45F	60	120	139	100	80	M12	101.9	25	13	15	10	16	B-PT1/8	10
HLG45FL			170.8				133.7	25						
HLG55F	70	140	163	116	95	M14	117.5	29	17	19	11	16	B-PT1/8	13
HLG55FL			201.1				155.6	29						

Ref No.	Dimensions of HLG Rail						Static Moment Capacity Nm			Weight			
	Width W1 ±0.05	W2	Height H1	Min G	Pitch P	d1 x d2 x h	C kN	Co kN	M	Mv	Ms	HLG Block kg	HLG Rail kg/m
HLG15F	15	16	13	10	60	4.5 x 7.5 x 5.3	9.9	16.2	115	115	129	0.19	1.3
HLG15FL							11.2	19.3	165	165	154	0.24	1.3
HLG20F	20	21.5	16.5	10	60	6 x 9.5 x 8.5	14.9	23.9	221	221	251	0.41	2.2
HLG20FL							17.8	30.6	369	369	322	0.54	2.2
HLG25F	23	23.5	20	10	60	7 x 11 x 9	22.1	33.1	337	337	398	0.61	3.0
HLG25FL							28.1	43.6	596	596	525	0.82	3.0
HLG30F	28	31	26	12	80	9 x 14 x 12	33.0	57.1	711	711	828	1.1	4.85
HLG30FL							40.9	73.6	1203	1203	1067	1.3	4.85
HLG35F	34	33	29	12	80	9 x 14 x 12	43.8	74.6	1062	1062	1298	1.6	6.58
HLG35FL							54.4	96.2	1797	1797	1674	2.01	6.58
HLG45F	45	37.5	38	16	105	14 x 20 x 17	70.6	92.8	2257	2257	1796	2.83	11.03
HLG45FL							87.6	126.5	3781	3781	2448	3.70	11.03
HLG55F	53	43.5	44	20	120	16 x 23 x 20	104.0	133.6	3810	3810	3094	4.36	15.26
HLG55FL							129.1	182.1	6410	6410	4220	5.76	15.26

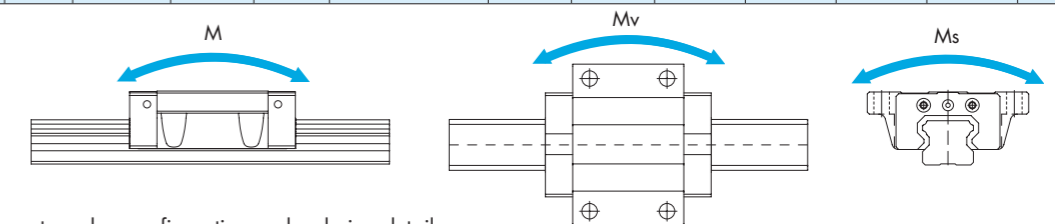

### Notes:

- See page 27 for part number configuration and ordering detail.
- For details of 1st hole position 'G' please see page 4.
- Size 15 blocks use a straight grease nipple (A-M4). Please see page 8 for more information.



# HLG--R Series, HLG--RL Series

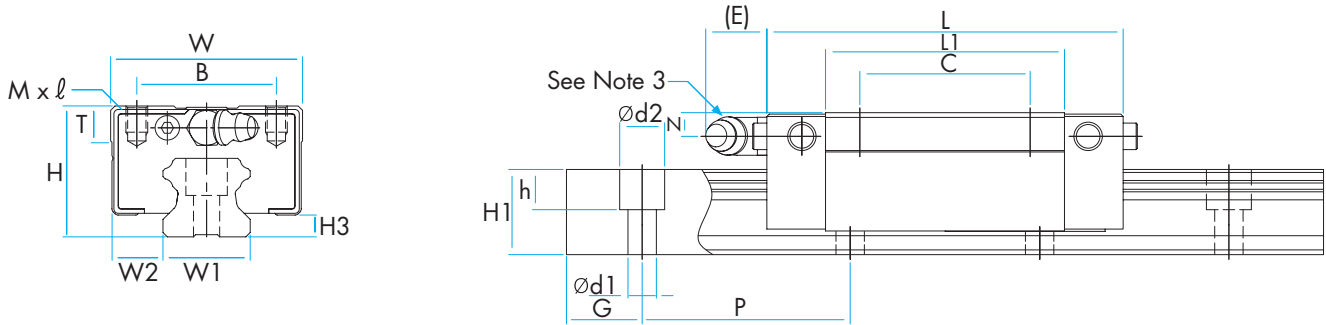

Ref No.	External Dimensions			Dimensions of HLG Block								H3
	Height H	Width W	Length L	B	C	M x	L1	T	N	E	Grease Nipple*3	
HLG15R	28	34	57	26	26	M4 x 5	40.8	6	10	6	A-M4	4.7
HLG15RL			65.3				49.1					
HLG20R	30	44	72.7	32	36	M5 x 6	53.1	8	7.5	12	B-M6F	6
HLG20RL			88.6				69					
HLG25R	40	48	83	35	35	M6 x 8	58.3	8	13	12	B-M6F	7
HLG25RL			102.9				78.2					
HLG30R	45	60	97.8	40	40	M8 x 10	70.8	8	10.3	12	B-M6F	7.5
HLG30RL			120				93					
HLG35R	55	70	110	50	50	M8 x 12	80.8	10	15	12	B-M6F	9
HLG35RL			135.4				106.2					
HLG45R	70	86	139	60	60	M10 x 17	101.9	15	20	16	B-PT1/8	10
HLG45RL			170.8				133.7					
HLG55R	80	100	163	75	72	M12 x 18	117.5	18	21	16	B-PT1/8	13
HLG55RL			201.1				155.6					

Ref No.	Dimensions of HLG Rail						Static Moment Capacity Nm			Weight			
	Width W1 ±0.05	W2	Height H1	Min G	Pitch P	d1 x d2 x h	C kN	Co kN	M	Mv	Ms	HLG Block kg	HLG Rail kg/m
HLG15R	15	9.5	13	10	60	4.5 x 7.5 x 5.3	9.9	16.2	115	115	129	0.18	1.3
HLG15RL							11.2	19.3	165	165	154	0.23	
HLG20R	20	12	16.5	10	60	6 x 9.5 x 8.5	14.9	23.9	221	221	251	0.31	2.2
HLG20RL							17.8	30.6	369	369	322	0.41	
HLG25R	23	12.5	20	10	60	7 x 11 x 9	22.1	33.1	337	337	398	0.53	3.0
HLG25RL							28.1	43.6	596	596	525	0.71	
HLG30R	28	16	26	12	80	9 x 14 x 12	33.0	57.1	711	711	828	0.9	4.85
HLG30RL							40.9	73.6	1203	1203	1067	1.1	
HLG35R	34	18	29	12	80	9 x 14 x 12	43.8	74.6	1062	1062	1298	1.5	6.58
HLG35RL							54.4	96.2	1797	1797	1674	2.01	
HLG45R	45	20.5	38	16	105	14 x 20 x 17	70.6	92.8	2257	2257	1796	2.89	11.03
HLG45RL							87.6	126.5	3781	3781	2448	3.74	
HLG55R	53	23.5	44	20	120	16 x 23 x 20	104.0	133.6	3810	3810	3094	4.28	15.26
HLG55RL							129.1	182.1	6410	6410	4220	5.59	

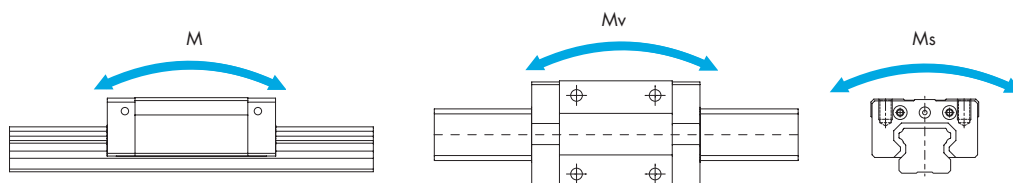

## Notes:

- See page 27 for part number configuration and ordering detail.
- For details of 1st hole position 'G' please see page 4.
- Size 15 blocks use a straight grease nipple (A-M4). Please see page 8 for more information.

# HLGS--C Series, HLGS--R Series

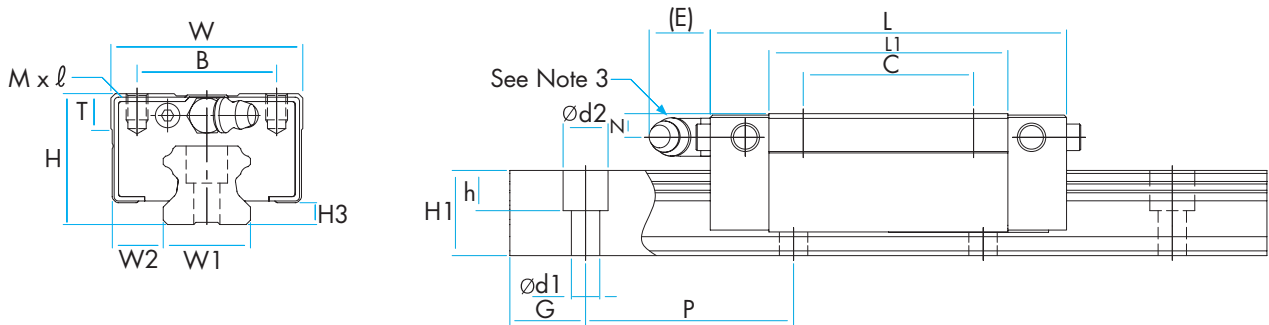

Ref No.	External Dimensions			Dimensions of HLG Block								H3
	Height H	Width W	Length L	B	C	M x	L1	T	N	E	Grease Nipple*3	
HLGS15C	24	34	40.2	26	-	M4 x 6	24	6	6	5.5	A-M4	4.5
HLGS15R			56.9		26		40.7					
HLGS20C	28	42	47.2	32	-	M5 x 7	27.6	7.5	5.5	12	B-M6F	6
HLGS20R			66.3		32		46.7					
HLGS25C	33	48	59.1	35	-	M6 x 9	34.4	8	6	12	B-M6F	7
HLGS25R			83		35		58.2					

Ref No.	Dimensions of HLG Rail					Static Moment Capacity Nm			Weight				
	Width W1 ±0.05	W2	Height H1	Min G	Pitch P	d1 x d2 x h	C kN	Co kN	M	Mv	Ms	HLG Block kg	HLG Rail kg/m
HLGS15C	15	9.5	13	10	60	4.5 x 7.5 x 5.3	6.5	9.3	39	39	74	0.096	1.3
HLGS15R							9.3	15.5	110	110	124	0.156	
HLGS20C	20	11	16.5	10	60	6 x 9.5 x 8.5	8.6	12.1	59	59	128	0.153	2.2
HLGS20R							12.3	20.2	165	165	213	0.246	
HLGS25C	23	12.5	20	10	60	7 x 11 x 9	13.9	19.0	115	115	229	0.254	3.0
HLGS25R							19.9	31.6	323	323	381	0.413	

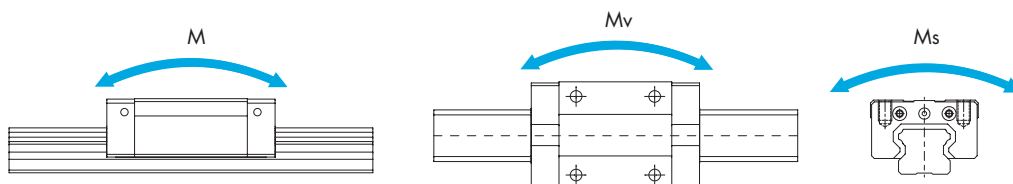

## Notes:

1. See page 27 for part number configuration and ordering detail.
2. For details of 1st hole position 'G' please see page 4.
3. Size 15 blocks use a straight grease nipple (A-M4). Please see page 8 for more information.

## HLGS--CF Series, HLGS--F Series

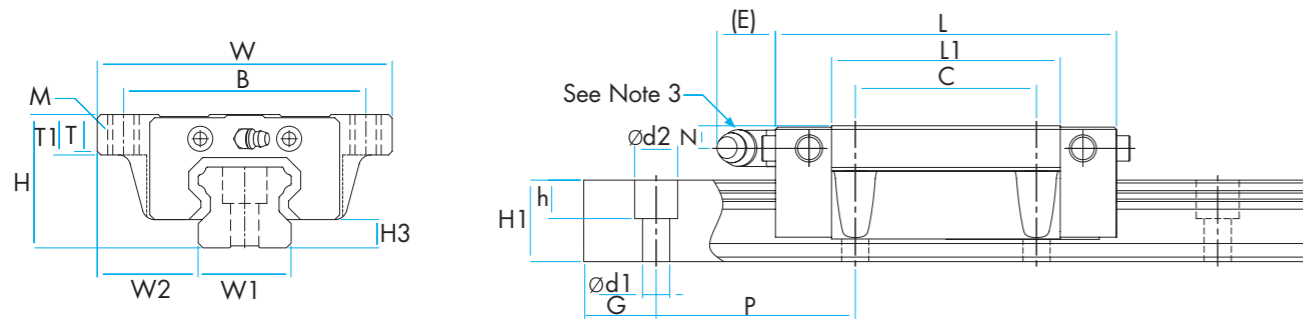

Ref No.	External Dimensions			Dimensions of HLG Block								H3
	Height H	Width W	Length L	B	C	M	L1	T	N	E	Grease Nipple*3	
HLGS15CF	24	52	40.2	41	-	M5	24	6	7	6	A-M4	4.5
HLGS15F			56.9		26		40.7					
HLGS20CF	28	59	47.2	49	-	M6	27.6	8	9	5.5	B-M6F	6
HLGS20F			66.3		32		46.7					
HLGS25CF	33	73	59.1	60	-	M8	34.4	9	10	6	B-M6F	7
HLGS25F			83		35		58.2					

Ref No.	Dimensions of HLG Rail						Basic Load Rating Dynamic / Static		Static Moment Capacity Nm			Weight	
	Width W1 $\pm 0.05$	W2	Height H1	Min G	Pitch P	d1 x d2 x h	C kN	Co kN	M	Mv	Ms	HLG Block kg	HLG Rail kg/m
HLGS15CF	15	18.5	13	10	60	4.5 x 7.5 x 5.3	6.5	9.3	39	39	74	0.125	1.3
HLGS15F							9.3	15.5	110	110	124	0.203	
HLGS20CF	20	19.5	16.5	10	60	6 x 9.5 x 8.5	8.6	12.1	59	59	128	0.187	2.2
HLGS20F							12.3	20.2	165	165	213	0.301	
HLGS25CF	23	25	20	10	60	7 x 11 x 9	13.9	19.0	115	115	229	0.320	3.0
HLGS25F							19.9	31.6	323	323	381	0.527	

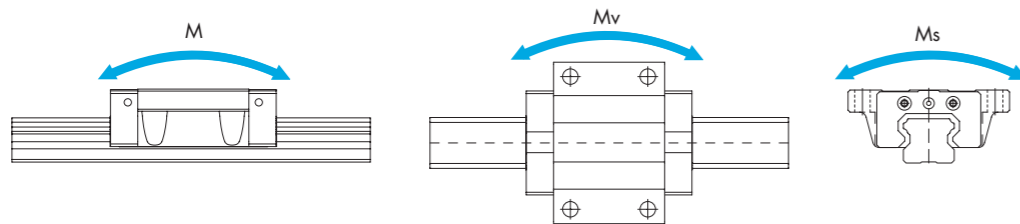

### Notes:

- See page 27 for part number configuration and ordering detail.
- For details of 1st hole position 'G' please see page 4.
- Size 15 blocks use a straight grease nipple (A-M4). See below for more information.

### Size 15 Block Grease Nipple (A-M4)

Size 15 blocks use a straight grease nipple instead of the standard 45° grease nipple used on other block sizes. The diagram below shows a size 15 block with a straight (A-M4) grease nipple.

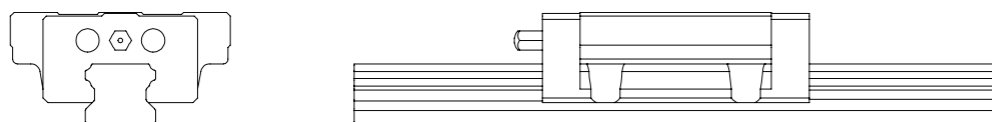

## Miniature MLG / MLGB Series

HepcoMotion's miniature guides have a four point contact ball recirculating system with 45° loading angles. There are two recirculating paths per carriage providing ultra smooth movement over the complete stroke length.

These precision units will provide exceptional load capacity in a very small space making them particularly suitable for a whole range of medical, scientific and small mechanical assembly systems where high performance is demanded.

With rails and blocks made from stainless steel as standard **MLG** and **MLGB** miniature guides are also suitable for use in clean rooms.

The standard **MLG** rail is available in sizes 5mm to 20mm. For applications where offset loads are present, a wider rail version is available (MLGB). Both options are part of HepcoMotion's standard stock range.

Both **MLG** and **MLGB** types are supplied with the blocks separate to the rails ready for mounting. To make assembly easy the balls are retained within the block by means of a wire retaining system.

Accuracy Grades		
'N'	Normal	(Stock Range)

Preload Grades		
'ZO'	Zero Preload	(Stock Range)
'Z1'	Light Preload	

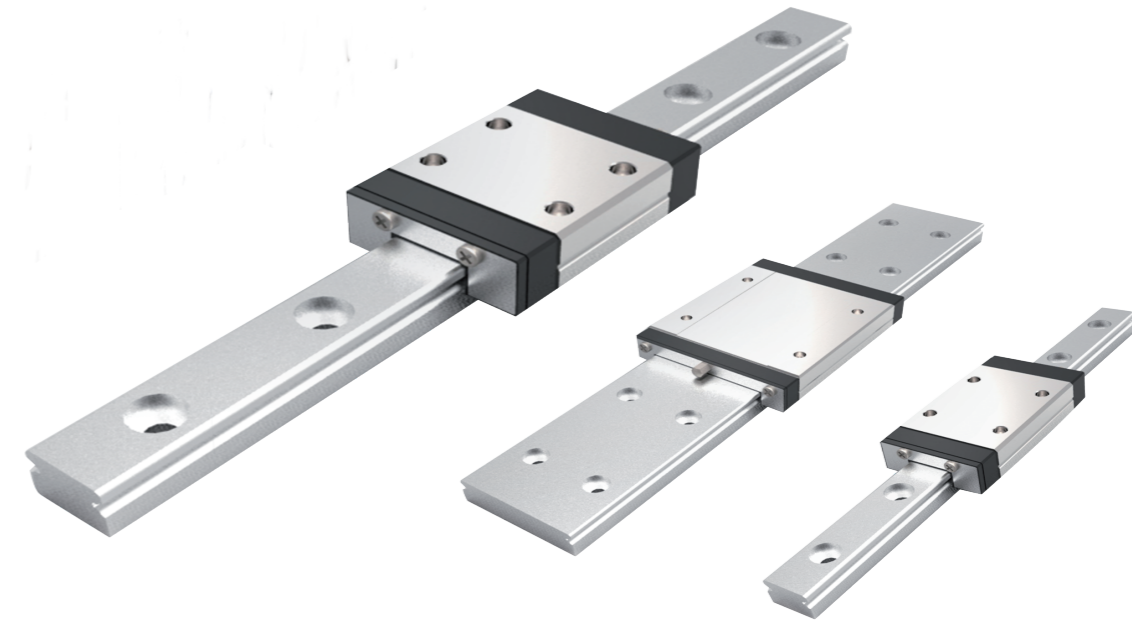

### Miniature Brakes

Manual clamping brakes are also available for all sizes of **MLG/MLGB**.

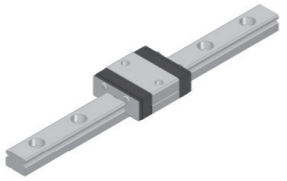
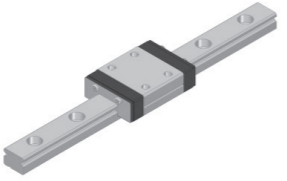
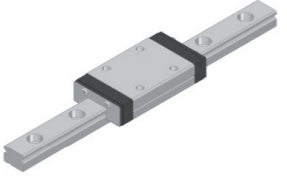
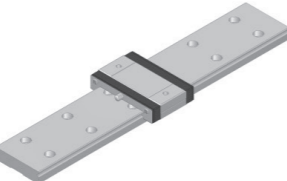
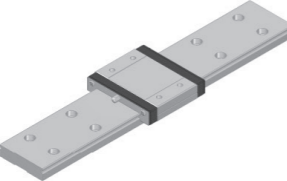
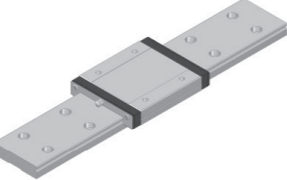

## Types and Features - Miniature Range (Stainless Steel)

Category	Type	Shape & Features
Compact type	MLGC	 Short Carriage
	MLGN	 Medium Carriage
	MLGL	 Long Carriage
Wide type	MLGBC	 Short Carriage
	MLGBN	 Medium Carriage
	MLGBL	 Long Carriage

**Standard & Wide Miniature Range**

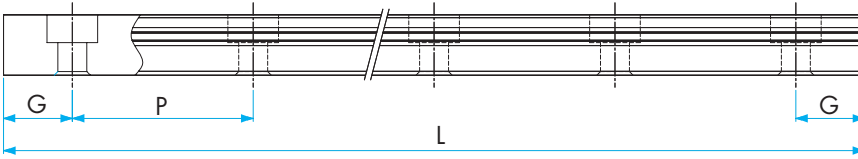

Model No.	MLG Standard Series						MLGB Wide Series				
	5	7	9	12	15	20	5	7	9	12	15
Standard Pitch P	15	15	20	25	40	60	20	30	30	40	40
G Min	5	5	7.5	8	8	10	5	5	7.5	8	8
Max. Length	1000	1000	1000	2000	2000	2000	1000	1000	1000	2000	2000

'G' is equal both ends unless otherwise specified.

## MLG Compact Miniature Series

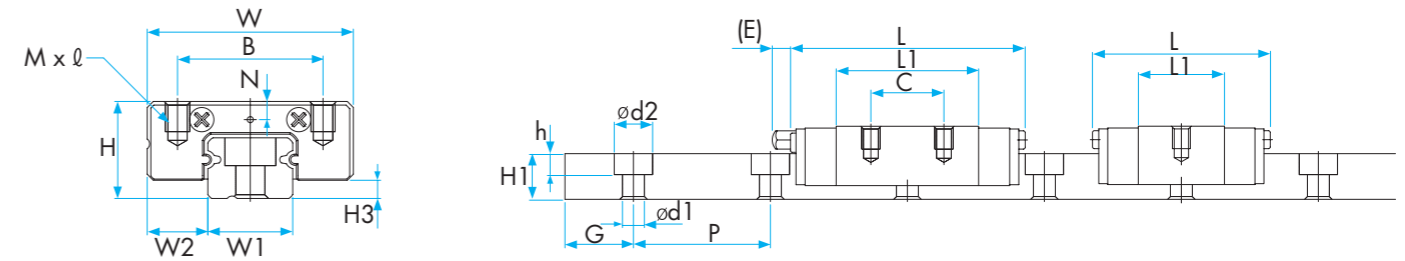

Ref No.	External Dimensions			Dimensions of MLG Block							H3
	Height H	Width W	Length L	B	C	M x $\ell$	L1	N	E	Grease Nipple	
MLG5C	6	12	17	8	-	M2 x 1.5	9.4	1.2	-	-	1
MLG5N			20		-		12.4		-		
MLG7C	8	17	19.8	12	-	M2 x 2.5	9.6	1.5	-	-	1.5
MLG7N			24.3		8		14.1		-		
MLG7L			31.8		13		21.6		-		
MLG9C	10	20	22.4	15	-	M3 x 3	11.8	2.2	-	-	2
MLG9N			31.3		10		20.7		-		
MLG9L			41.4		15		30.8		-		
MLG12C	13	27	26.4	20	-	M3 x 3.5	12.8	2.7	-	-	3
MLG12N			34.9		15		21.3		-		
MLG12L			45.4		20		31.8		-		
MLG15C	16	32	34.4	25	-	M3 x 4	17.7	3.1	4	-	4
MLG15N			44.4		20		27.7		4	A-M3	
MLG15L			59.4		25		42.7		4		
MLG20C	20	40	39.8	30	-	M4 x 6	22.2	4.2	4	-	5
MLG20N			51.8		25		34.2		4	A-M3	
MLG20L			69.8		30		52.2		4		

Ref No.	Dimensions of MLG Rail						Basic Load Rating		Static Moment Capacity			Weight	
	Width W1 $\pm 0.05$	W2	Height H1	Min G	Pitch P	d1 x d2 x h	C N	C <sub>0</sub> N	M	M <sub>v</sub>	M <sub>s</sub>	MLG Block g	MLG Rail g/m
MLG5C	5	3.5	3.7	5	15	2.4 x 3.6 x 0.8	516.9	757.1	1.27	1.27	1.8	3.1	139
MLG5N							632.1	1009.4	2.25	2.25	2.35	4.0	
MLG7C							924.2	1135.6	1.9	1.9	3.6	6.4	
MLG7N	7	5	5	5	15	2.4 x 4.2 x 2.3	1227.1	1703.4	4.3	4.3	5.4	9.0	253
MLG7L							1671.6	2649.7	10.2	10.2	8.4	12.6	
MLG9C	9	5.5	6	7.5	20	3.5 x 6 x 3.5	1162.6	1484.9	3.1	3.1	6.1	9.9	391
MLG9N							1697.0	2545.5	9.3	9.3	10.5	17.1	
MLG9L							2337.1	4030.3	22.1	22.1	16.6	25.2	
MLG12C	12	7.5	8	8	25	3.5 x 6.5 x 4.5	2181.7	2384.8	5.4	5.4	12.9	19.8	679
MLG12N							3035.6	3815.6	14.3	14.3	20.7	31.5	
MLG12L							4254.0	6200.4	35.3	35.3	33.6	45.9	
MLG15C	15	8.5	10	8	40	3.5 x 6.5 x 4.5	3443.1	3895.2	12.2	12.2	26.6	37.8	1071
MLG15N							4579.3	5842.8	28.7	28.7	39.9	57.6	
MLG15L							6533.6	9738.1	74.7	74.7	66.5	85.5	
MLG20C	20	10	11	10	60	6 x 9.5 x 5.5	4516.5	5299.4	20.7	20.7	48.7	80.1	1572
MLG20N							6194.8	83277.6	50.4	50.4	76.6	119.7	
MLG20L							8400.1	12870.0	119	119	118	176.4	

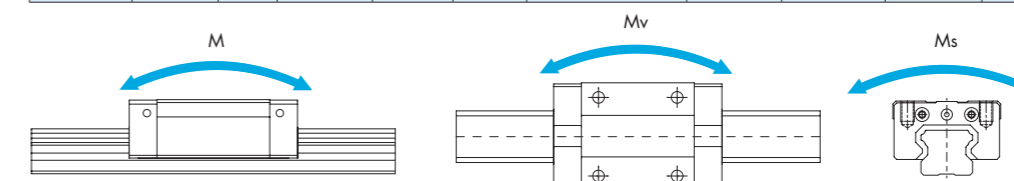

- Notes:**
- See page 27 for part number configuration and ordering detail.
  - For detail of 1st hole position 'G' please see page 10.



## MLGB Wide Miniature Series

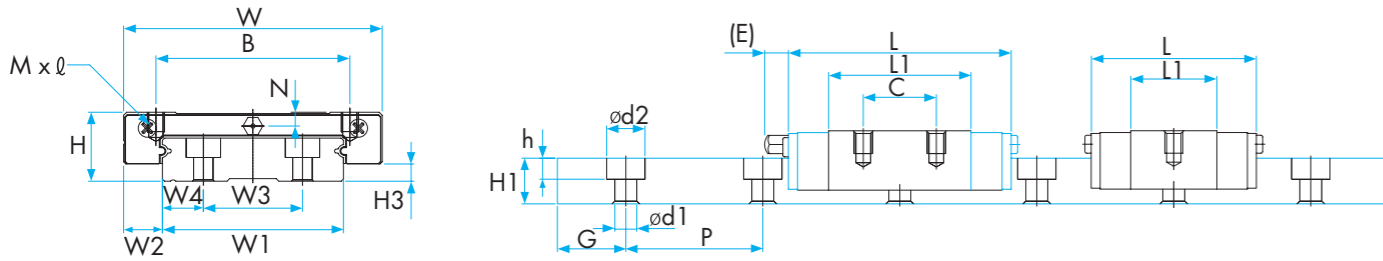

Ref No.	External Dimensions			Dimensions of MLG Block							H3
	Height H	Width W	Length L	B	C	M x l	L1	N	E	Grease Nipple	
MLGB5C	6.5	17	21	13	-	M2.5 x 1.5	13.4	1.4	-	-	1.3
MLGB5N			25		-		17.4		-		
MLGB7C	9	25	24	19	-	M3 x 3	12.6	1.7	-	-	2
MLGB7N			33		10		21.6		-		
MLGB7L			43.5		19		32.1		-		
MLGB9C	12	30	28.1	21	-	M3 x 3.5	16.5	3.2	-	-	3
MLGB9N			40.2		12		28.6		-		
MLGB9L			52		24		40.4		-		
MLGB12C	14	40	31.1	28	-	M3 x 3.5	17.5	3.2	-	-	3
MLGB12N			44.5		15		30.9		-		
MLGB12L			59.7		28		46.1		-		
MLGB15C	16	60	42.8	45	-	M4 x 4.5	25.2	3.2	4	-	4
MLGB15N			56.6		20		39		4	A-M3	
MLGB15L			75.8		35		58.2		4		

Ref No.	Dimensions of MLG Rail							Basic Load Rating		Static Moment Capacity Nm			Weight		
	Width W1 ±0.05	W2	W3	W4	Height H1	Min G	Pitch P	d1 x d2 x h	C N	Co N	M	Mv	Ms	MLG Block g	MLG Rail g/m
MLGB5C	10	3.5	-	5	4	5	20	2.9 x 4.8 x 1.6	668	1094	4.0	4.0	5.6	5.3	299
MLGB5N									806	1430	6.3	6.3	7.3	6.8	
MLGB7C	14	5.5	-	7	5.5	5	30	3.5 x 6 x 3.2	1102	1514	6.4	6.4	10.8	11.7	560
MLGB7N									1631	2650	15.4	15.4	18.0	18.9	
MLGB7L									2166	3975	30.5	30.5	28.4	27.9	
MLGB9C	18	6	-	9	7	7.5	30	3.5 x 6 x 4.5	1515	2121	10.5	10.5	19.4	23.4	912
MLGB9N									2197	3606	25.5	25.5	33.0	39.6	
MLGB9L									2878	5303	48.6	48.6	48.5	54.9	
MLGB12C	24	8	-	12	8	8	40	4.5 x 8 x 4.5	2753	3339	18.3	18.3	40.7	40.5	1369
MLGB12N									4015	5723	44.9	44.9	69.8	68.4	
MLGB12L									5539	9062	95.5	95.5	110.5	99.9	
MLGB15C	42	9	23	9.5	10	15	40	4.5 x 8 x 4.5	4954	6056	45.7	45.7	128	85.5	2886
MLGB15N									6579	9085	90.7	90.7	192	126.0	
MLGB15L									9076	14384	192	192	304	183.6	

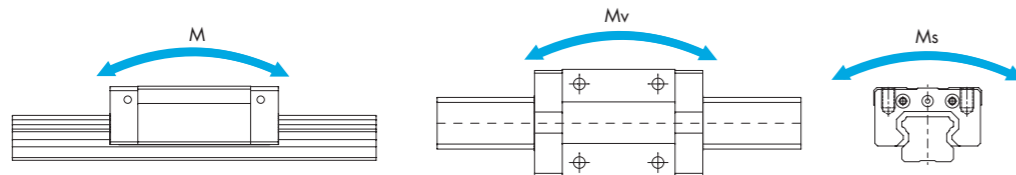

### Notes:

- See page 27 for part number configuration and ordering detail.
- For details of 1st hole position 'G' please see page 10.

## HLG Brake Option

The HepcoMotion **HLG** Brake provides a compact, and simple method of locking a **HLG** Bearing Block in position. The brake is intended for manual locking of a stationary block, and can be supplied with a range of brake plates to suit most of the **HLG** bearing block options. When the brake is applied the resulting clamping force does not impose any load upon the bearing block.

Although tailored to suit Hepco **HLG** Linear Ball Guides, the brake is equally compatible with other ball guide systems, and is manufactured with stainless steel components\*<sup>1</sup>.

Dimensions for all sizes are on pages 14-16. For information on how to select a **HLG** brake or details on a specific application please contact Hepco's technical department.

### For MLG Brakes go to page 9

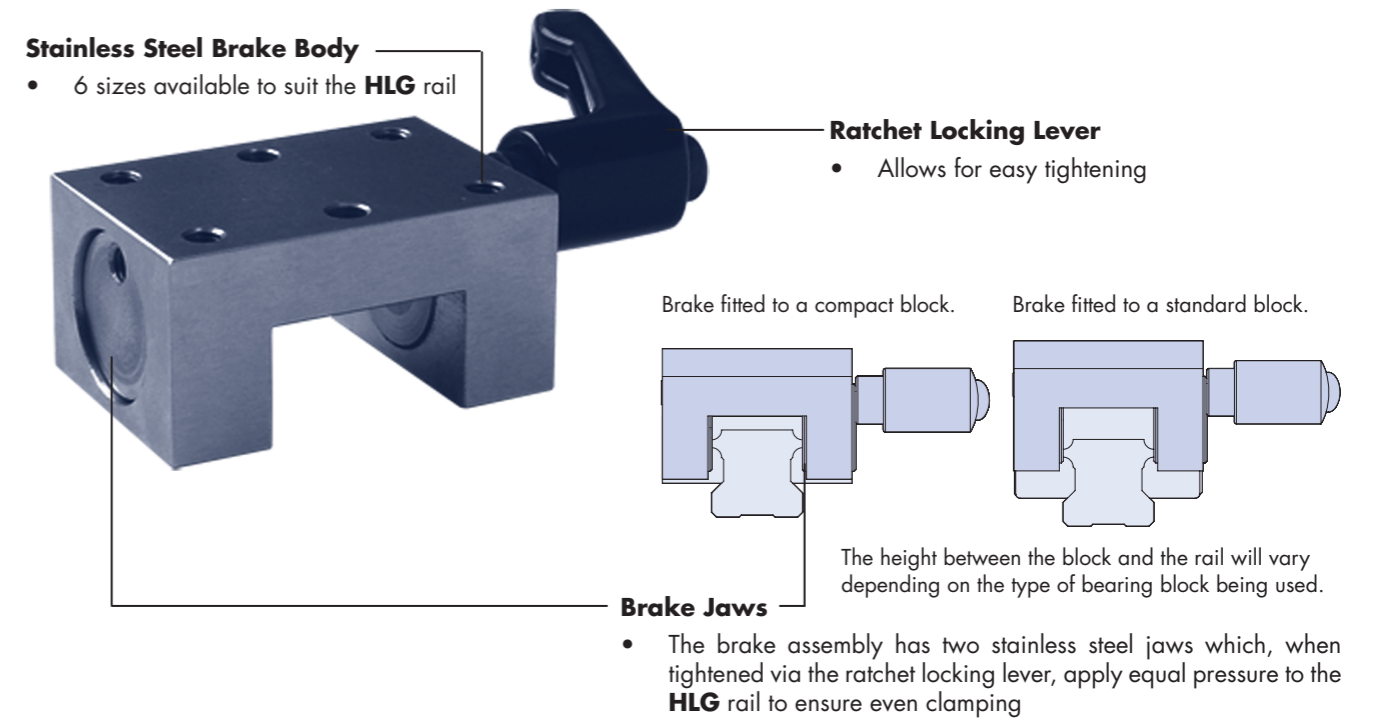

### Brake Plate (Optional)

- Used to secure the brake to the **HLG** block
- Available in a wide range of sizes

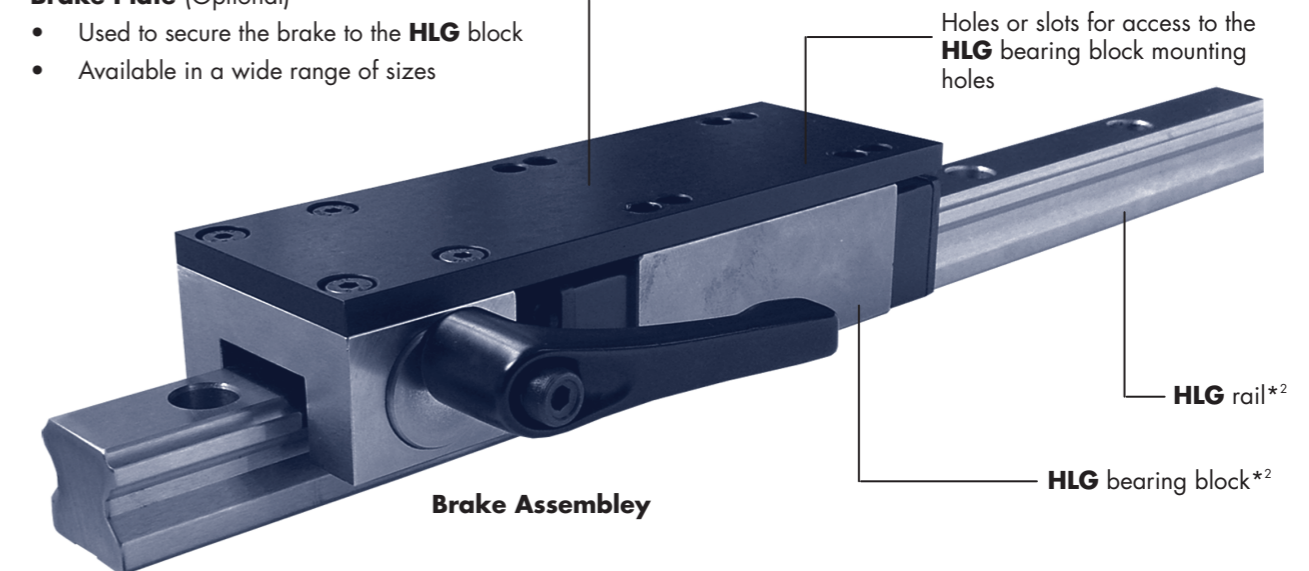

### Notes:

- The ratchet locking lever of the HLG15B and HLG20B brakes contain a steel threaded insert and is not available in stainless steel.
- Please note **HLG** block and rail are shown for clarity only and not included as part of the brake assembly.

## HLG Brake Option

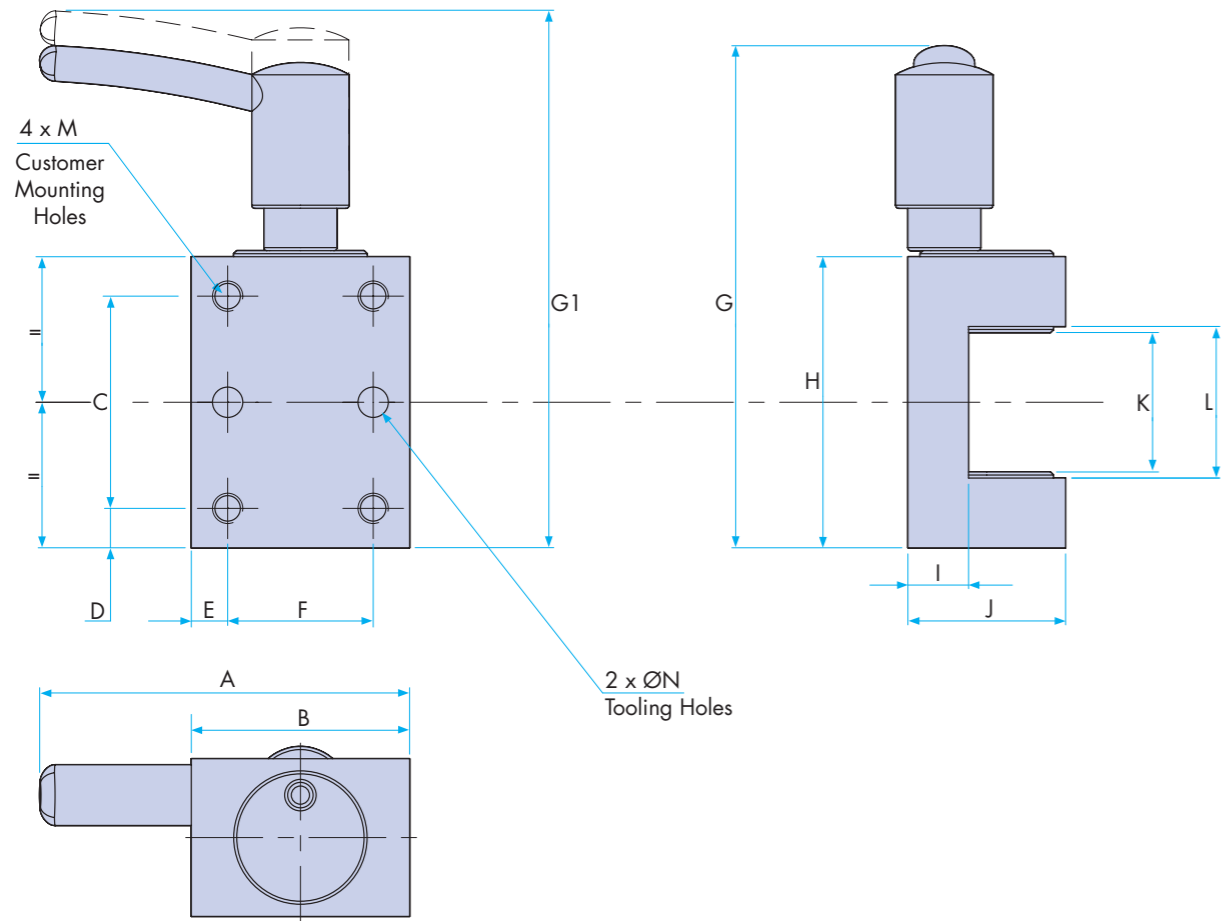

HLG Brake	For use with HLG Rail Size	A	B	C	D	E	F	G <sup>1</sup>	G1 <sup>2</sup>	H	I	J	Kmax <sup>2</sup>	Kmin <sup>1</sup>	L	M	N
HLG15B	15	56	28	22	6	5	18	72	76	34	9	19.5	17	15	17	M4 x 5 Dp	Ø4 x 5 Dp
HLG20B	20	58	30	32	6	5	20	82	86	44	9	22	22	20	22	M4 x 5 Dp	Ø4 x 5 Dp
HLG25B	25	61	36	35	6.5	6	24	79	83	48	10	26	25	23	25	M5 x 6 Dp	Ø5 x 6 Dp
HLG30B	30	85	38	40	10	6.5	25	104	110	60	15	33	30	28	30	M6 x 8 Dp	Ø6 x 7 Dp
HLG35B	35	89	46	50	10	7	32	115	121	70	18	38.5	36	34	36	M6 x 8 Dp	Ø6 x 7 Dp
HLG45B	45	90	50	60	13	8	34	132	138	86	21	46	47	45	47	M6 x 8 Dp	Ø6 x 7 Dp

### Ordering Details - Brake only

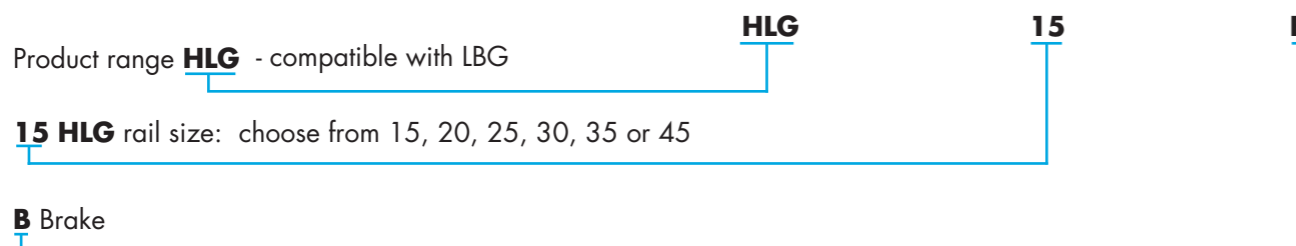

#### Notes:

- Dimensions G and Kmin are measured with the brake fully tightened against the rail.
- Dimensions G1 and Kmax are measured with the brake released and the handle in the disengaged position.

## Brake Plate - for HLG Blocks without flange

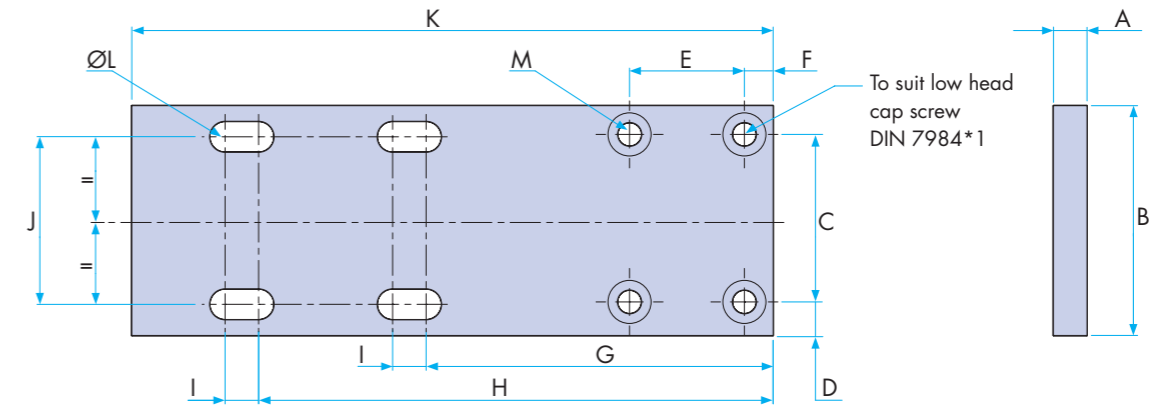

HLG Brake Plate	For use with HLG Block	A	B	C	D	E	F	G	H	I	J	K	ØL	M		
														C/Bore Ø	Depth	Hole Ø
HLG20BP1	HLG20R HLG20RL	5	44	32	6	20	5	61	93	6.5	32	117	5.5	7.5	3	4.5
HLG25BP1	HLG25R HLG25RL	7	48	35	7	24	6	72.5	107.5	7	35	134	6.5	9	3.8	5.5
HLG25BP2	HLG25RL	7	48	35	7	24	6	76	126	4.5	35	156	6.5	9	3.8	5.5
HLG30BP1	HLG30R	8	60	40	10	25	6.5	82.5	122.5	3.5	40	157	8.5	10.5	4.3	6.5
HLG30BP2	HLG30RL	8	60	40	10	25	6.5	83.6	143.6	4.9	40	179	8.5	10.5	4.3	6.5
HLG35BP1	HLG35R	8	70	50	10	32	7	90.5	140.5	6.5	50	175	8.5	10.5	4.3	6.5
HLG35BP2	HLG35RL	8	70	50	10	32	7	92.4	164.4	8.6	50	200	8.5	10.5	4.3	6.5
HLG45BP2	HLG45RL	8	86	60	13	34	8	106.5	186.5	5.5	60	233	10.5	10.5	4.3	6.5

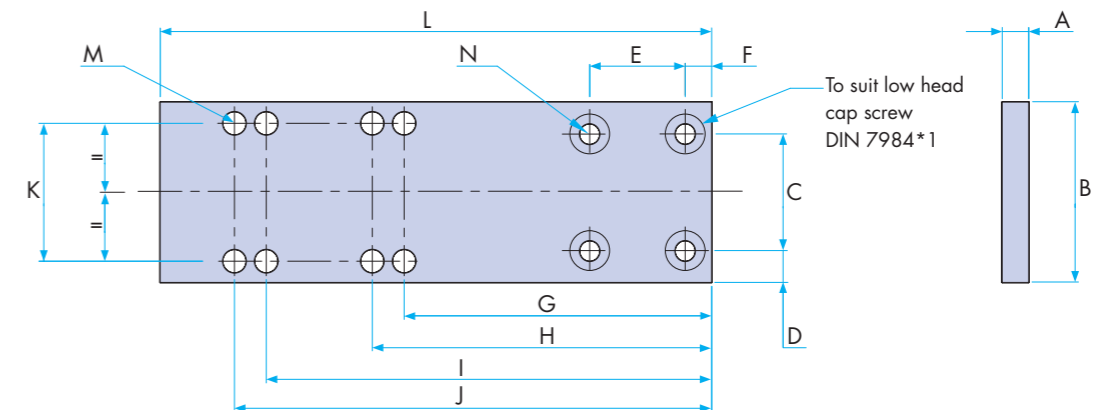

HLG Brake Plate	For use with HLG Block	A	B	C	D	E	F	G	H	I	J	K	L	M <sup>2</sup>	N		
															C/Bore Ø	Depth	Hole Ø
HLG15BP1	HLG15R HLG15RL HLG15RL	5	34	22	6	18	5	58	64	84	92	26	104	8 x Ø4.5	7.5	3	4.5
HLG15BP3	HLG15C	5	34	22	6	18	5	61.8	-	-	-	26	84	2 x Ø4.5	7.5	3	4.5
HLG20BP3	HLG20C	5	44	32	6	20	5	69	-	-	-	32	97	2 x Ø5.5	7.5	3	4.5
HLG20BP2	HLG20RL	5	44	32	6	20	5	61.2	68	111.2	118	32	130	8 x Ø5.5	7.5	3	4.5
HLG25BP3	HLG25C	7	48	35	6.5	24	6	77.25	-	-	-	35	107	2 x Ø6.5	9	3.8	5.5
HLG45BP1	HLG45R	8	86	60	13	34	8	104	164	-	-	60	208	4 x Ø10.5	10.5	4.3	6.5

#### Notes:

- Low head cap screws to DIN 7984 are available from Hepco on request.
- Not all brake plates will have eight holes due to the size of the block to which they fit. The number of holes each will have is as shown in column M.
- Plates are fully machined from aluminium alloy and supplied black anodised.

## Brake Plates - for HLG Blocks with Flange

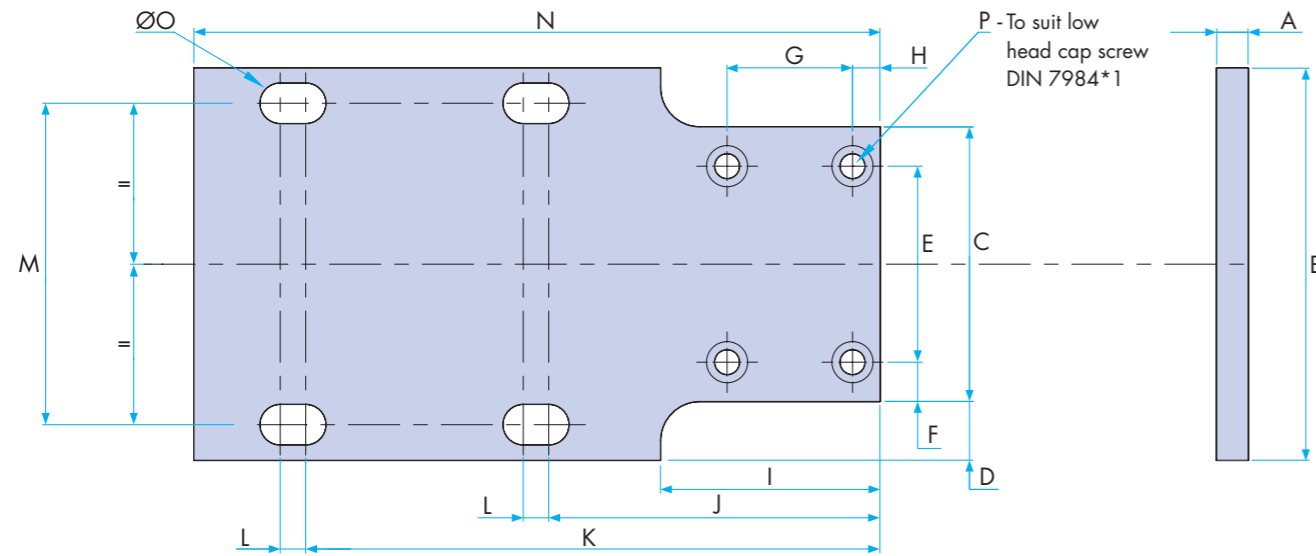

HLG Brake Plate*	For use with HLG Block	A	B	C	D	E	F	G	H	I	J	K	L	M	N	ØO	P		
																	C/Bore Ø	Depth	Hole Ø
HLG15BP4	HLG15F	5	47	34	6.5	22	6	18	5	38	56	86	6	38	104	5.5	7.5	3	4.5
HLG20BP4	HLG20F	5	63	44	9.5	32	6	20	5	40	58.9	98.9	4.6	53	117	6.5	7.5	3	4.5
HLG20BP5	HLG20FL	5	63	44	9.5	32	6	20	5	40	66.2	106.2	6.8	53	132	6.5	7.5	3	4.5
HLG25BP4	HLG25F	7	70	48	11	35	7	24	6	46	67.5	112.5	7	57	134	8.5	9	3.8	5.5
HLG25BP5	HLG25FL	7	70	48	11	35	7	24	6	46	78.5	123.5	4.5	57	156	8.5	9	3.8	5.5
HLG30BP4	HLG30F	8	90	60	15	40	10	25	6.5	48	76.5	128.5	3.5	72	157	10.5	10.5	4.3	6.5
HLG30BP5	HLG30FL	8	90	60	15	40	10	25	6.5	48	87.5	139.5	5	72	179	10.5	10.5	4.3	6.5
HLG35BP4	HLG35F	8	100	70	15	50	10	32	7	56	84.5	146.5	6.5	82	175	10.5	10.5	4.3	6.5
HLG35BP5	HLG35FL	8	100	70	15	50	10	32	7	56	97.4	159.4	8.6	82	200	10.5	10.5	4.3	6.5
HL45BP4**2	HLG45F	8	120	86	17	60	13	34	8	60	94.1	174.1	-	100	208	12.5	10.5	4.3	6.5
HLG45BP5	HLG45FL	8	120	86	17	60	13	34	8	60	106.5	186.5	5.5	100	233	12.5	10.5	4.3	6.5

### Notes:

1. Low head cap screws to DIN 7984 are available from Hepco on request.
2. This brake plate will have through holes instead of slots, in the positions as detailed above.
3. Plates are fully machined from aluminium alloy and supplied black anodised.

### Ordering Details - Brake plate only

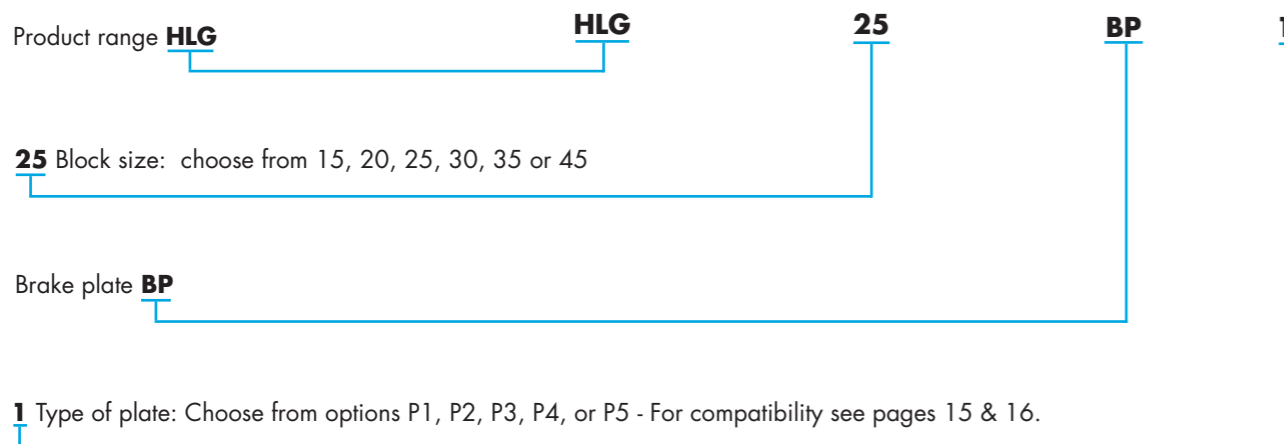

The **HLG** brake and brake plates are also available as a complete assembly as shown at the bottom of page 13. Please contact Hepco's technical department for more information.

## Life Calculation

The basic dynamic load rating of linear guides is based on a constant one directional load that provides 50Km of linear travel. This is the distance at which 10% of guides will show signs of fatigue pitting of the block or rail tracks necessitating replacement.

The 50Km travel load rating shown in the catalogue is used to calculate the life of the system under normal operating conditions.

Factors will be applied to the calculation where necessary:

- Where two blocks are used on the same rail ( $f_c$ )
- A factor for the type of load ( $f_v$ )

The life achieved can also be affected by:

- Excess load by inaccurate assembly
- Contamination within the block
- High speed short stroke motion with excessive load
- Damage to the end plates

Fatigue life L

$$L = \left( \frac{f_c \cdot C}{f_v \cdot P} \right)^3 \times 50$$

L : Fatigue life (km)

C : Basic dynamic load rating (N)

P : Applied load (N)

$f_c$ : Contact factor

$f_v$ : Load factor

### Contact Factor

Where two or more Blocks are used in close proximity or where there is a mounting surface variation – multiply the stated basic load ratings ( $f_c$ ) by the mounting factor.

Contact Factor	Contact Factor ( $f_c$ )
2	0.81
3	0.72
4	0.66
5	0.61
Over 6	0.60

### Load Factor

In cases of additional forces from vibration or impact being applied the following factors will need to be applied to the calculation.

Impact and Vibration Condition	Travel Speed Velocity (V)	$f_v$
No External Impact or Vibration	$V \leq 15m / min$ Low Speed	1 - 1.5
Slight Impact and Vibration	$15 < V \leq 60m / min$ Medium Speed	1.5 - 2.0
Medium Impact and Vibration	$V > 60m / min$ High Speed	2.0 - 3.5

### Basic static load rating $C_0$

Excessive static loads can cause permanent deformation of the rolling element and raceway surface.

The static load rating  $C_0$  is the static load of constant magnitude, acting in one direction at which permanent deformation of the element and raceway surface equivalent to 0.0001 times the ball diameter will occur.

## Preload and Rigidity

**HLG** recirculating ball guides are by design, inherently rigid and are supplied in three preload levels. The preload function is to eliminate clearance between the block and rail running surfaces by the insertion of a ball larger than the space available.

The rigidity of the block is a function of the preload level and in normal applications Z0 (zero / light preload) or Z1 (light preload) will suffice. For machining or higher impact applications subject to high moment loads, Z2 is best selected (medium preload).

Type	Preload type	Preload type	Equivalent preload force
<b>HLG</b>	Z0	Zero / Light (Stock Range)	0 – 0.03 x C
<b>HLG</b>	Z1	Light (Stock Range)	0.04 – 0.08 x C
<b>HLG</b>	Z2	Medium	0.09 – 0.13 x C

<b>HLGS</b>	Z0	Zero / Light (Stock Range)	0 – 0.03 x C
<b>HLGS</b>	Z1	Light (Stock Range)	0.03 – 0.05 x C
<b>HLGS</b>	Z2	Medium	0.06 – 0.08 x C

The equivalent preload force is the force being applied within an individual block caused by the elastic deformation of the balls where C is the Basic Dynamic Load Rating.

### Frictional Resistance

The frictional resistance of a block is determined by the applied load multiplied by the coefficient of friction stated as a friction factor. In lightly loaded applications the seals can have a significant effect on the final calculated figure.

The frictional resistance can be calculated from the following:

$$F = \mu \times P + f_s$$

### Seal Resistance $f_s$

Ref No	Seal resistance (N) per block
<b>HLG15</b>	2N
<b>HLG20</b>	4N
<b>HLG25</b>	4N
<b>HLG30</b>	6N
<b>HLG35</b>	11N
<b>HLG45</b>	19N
<b>HLG55</b>	19N

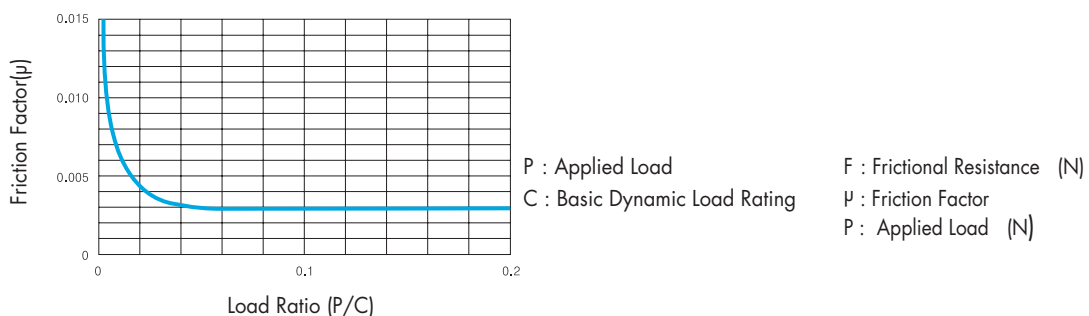

Figure 1. Relation between load ratio & friction factor



## Precision HLG, HLGS

The accuracy of travel of **HLG** recirculating ball guides is measured as shown below (see figure 2)

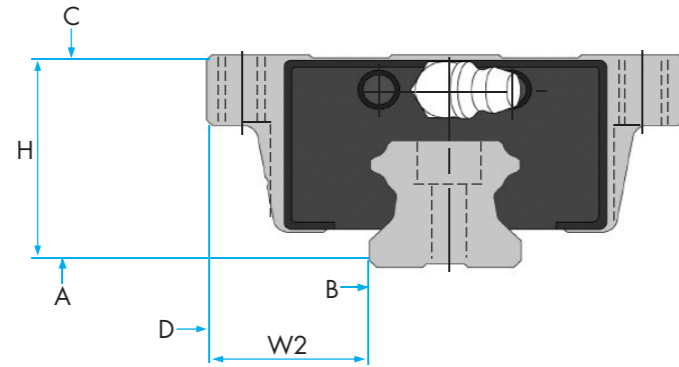

Figure 2. Block measurement

Table 1. Classification of precision

Unit : mm

Dimension	Terms
Dimension tolerance of height H	Distance from the base side of rail A to the top side of block C
Difference in height H	Difference in the height of blocks combined from each rail on the same plane
Dimension tolerance of width W2	Distance between the datum plane of rail B and the reference side of block D
Difference in width W2	Difference of the reference axis of rail B and the reference side of block D of blocks combined to the rail
Parallelism of motion of C against A	Change in the top side of block C based on the base side of rail A during the motion of block combined to the rail
Parallelism of motion of D against B	Change in the reference side of block D based on the reference side of rail B during the motion of block combined to the rail

Table 2. Specification for precision of guide (**HLG, HLGS**)

Unit : mm

Dimension	Normal	High	Precision	Super Precision	Ultra Precision
	No symbol	H	P	SP	UP
		P6	P5	P4	P3
Dimension tolerance of height H	±0.080	±0.042	±0.020	±0.010	±0.008
Difference in height H	0.025	0.015	0.007	±0.010	0.003
Dimension tolerance of width W2	±0.100	±0.050	±0.025	±0.015	±0.010
Difference in width W2	0.030	0.020	0.010	0.007	0.003
Parallelism of motion of C against A	See Table 4				
Parallelism motion of D against B	See Table 4				

## Precision MLG, MLGB

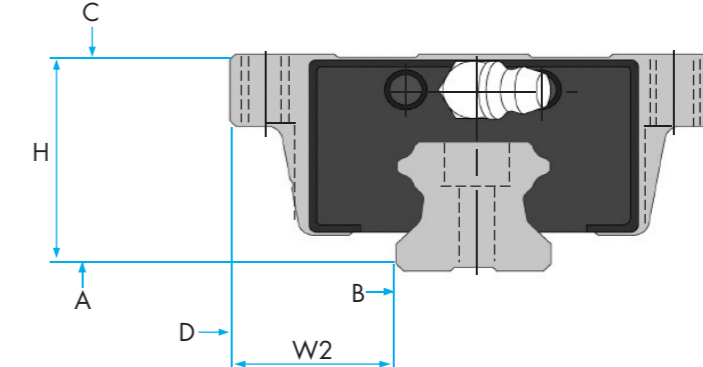

Figure 3. Block measurement

Table 3. Specification for precision of miniature guide (**MLG, MLGB**)

Model Size	Precision Dimension	Normal	High	Precision
		Difference in height H	P6	P5
5	Dimension tolerance of height H	±0.030	-	±0.015
	Difference in height H	0.015	-	0.005
	Dimension tolerance of width W2	±0.030	-	±0.015
	Difference in width W2	0.015	-	0.05
	Parallelism of motion of C against A	See Table 5		
	Parallelism motion of D against B	See Table 5		
7 9 12 15 20	Dimension tolerance of height H	±0.040	±0.020	±0.010
	Difference in height H	0.030	0.015	0.007
	Dimension tolerance of width W2	±0.040	±0.025	±0.015
	Difference in width W2	0.030	0.020	0.010
	Parallelism of motion of C against A	See Table 5		
	Parallelism motion of D against B	See Table 5		

## Surface Treatment

**HLG** recirculating ball guides are available in a number of corrosion resistant treatments depending on application requirements and cost. Hard chrome plating is the least expensive process and will provide a level of protection in environments where water vapour is present.

For improved protection, Raydent is a low temperature black coating that has proved to work equally well in clean rooms and in conditions where the rail is subject to water spray. In all applications where water is present it is recommended to conduct a short trial in the installation to ensure that the requirements can be met. We can assist with the supply of samples for test purposes. Please contact our sales department for further advice on applications requiring corrosion resistance.

### Notes:

1. See page 27 for part number configuration and ordering detail.

Table 4. Length of rail and parallelism of motion of guide (HLG, HLG-S)

Length of Rail		Parallelism of Motion				
Above	Below	Normal	High	Precision	Super Precision	Ultra Precision
		No symbol	H	P		
			P6	P5	P4	P3
-	50	5	3	2	1.5	1
50	80	5	3	2	1.5	1
80	125	5	3	2	1.5	1
125	200	5	3.5	2	1.5	1
200	250	6	4	2.5	1.5	1
250	315	7	4.5	3	1.5	1
315	400	8	5	3.5	2	1.5
400	500	9	6	4.5	2.5	1.5
500	630	11	7	5	3	2
630	800	12	8.5	6	3.5	2
800	1000	13	9	6.5	4	2.5
1000	1250	15	11	7.5	4.5	3
1250	1600	16	12	8	5	4
1600	2000	18	13	8.5	5.5	4.5
2000	2500	20	14	9.5	6	5
2500	3150	21	16	11	6.5	5.5
3150	4000	23	17	12	7.5	6

Table 5. Length of rail and parallelism of motion of miniature guide (MLG, MLGB Series)

Length of Rail		Parallelism of Motion		
Above	Below	Normal	High	Precision
		No symbol	H	P
			P6	P5
-	40	8	4	1
40	70	10	4	1
70	100	11	4	2
100	130	12	5	2
130	160	13	6	2
160	190	14	7	2
190	220	15	7	3
220	250	16	8	3
250	280	17	8	3
280	310	17	9	3
310	340	18	9	3
340	370	18	10	3
370	400	19	10	3

Length of Rail		Parallelism of Motion		
Above	Below	Normal	High	Precision
		No symbol	H	P
			P6	P5
400	430	20	11	4
430	460	20	12	4
460	490	21	12	4
490	520	21	12	4
520	550	22	12	4
550	700	22	12	4
700	820	23	14	5
1000	1180	25	16	5
1180	1360	26	17	6
1360	1420	27	18	6
1420	1510	27	18	7
1510	1800	28	19	7

HLG recirculating ball guides require effective lubrication to be present within the block at all times to prevent premature wear. Blocks can be lubricated with a suitable grease or oil. In most industrial applications grease is commonly used due to the longevity between re-lubrication intervals and cleanliness factors. Oil based lubrication normally requires an automatic lubrication system to be installed for maximum effect. For normal applications lithium soap based greases are commonly used but synthetic greases are also acceptable. The re-lubrication interval can be affected by environmental and other service conditions but is generally after 100 km of travel. This can also be expressed in hours according to the following formula.

$$T = \frac{100 \times 1000}{V_e \times 60} \quad \text{Where } T = \text{Time in hours}$$

$$V_e = \text{Velocity (m/min)}$$

A 400g grease cartridge can be ordered under part no. SH45004973

### Bleed Lubrication

Bleed lubrication provides an alternative, low maintenance, way of lubricating blocks. Blocks are moved to a maintenance position over lubrication passages drilled into the guide rail. The blocks can then be charged remotely through pipe work fitted to the carriage via a grease gun or an automatic dosing pump. The bleed lubrication option is available on ball guides from sizes 15 to 55. **Please state the required position of the lubricant passages when ordering.**

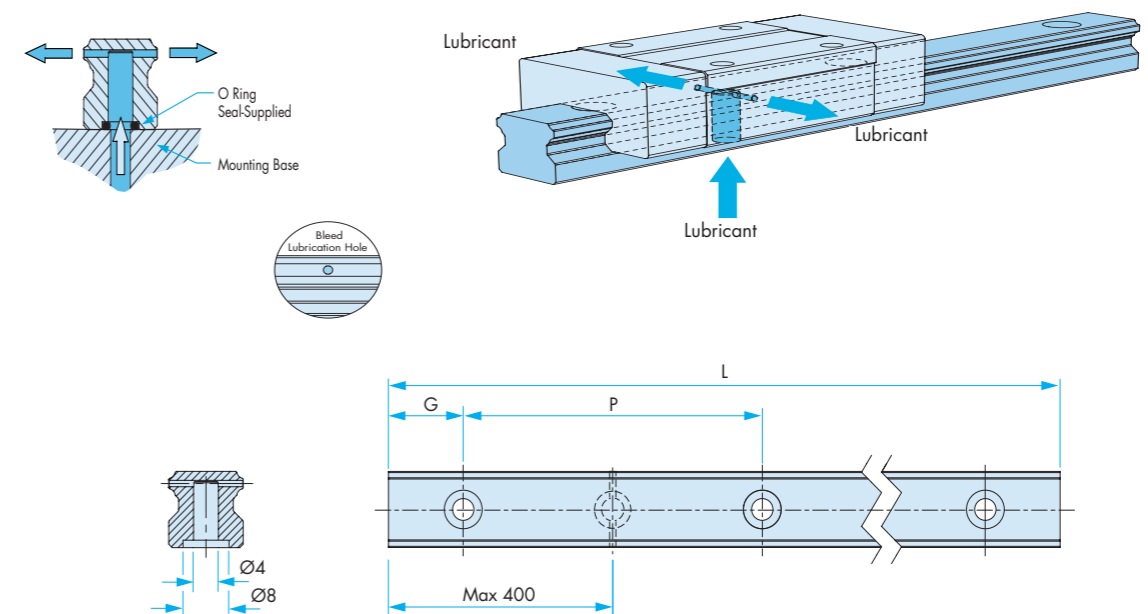

### Ordering Details

Please refer to page 27 for specific ordering information. To include bleed lubrication add HLGBL x (the number of locations required) to the rail part number.

For example - HLGBL x 2, where 2 is the number of locations.

Specify the location of each bleed lubrication hole as a distance from the cut end. Observe hole positions detailed on page 4 and ensure that the bleed lubrication holes do not conflict with the rail fixing holes.

## Sealing Options and Railcaps

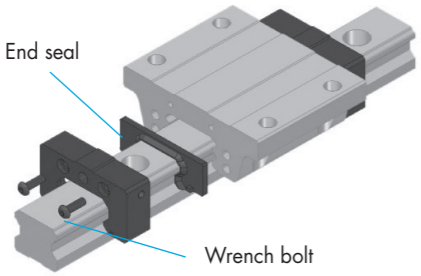
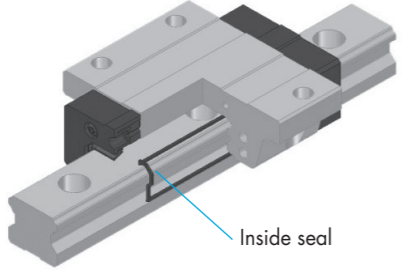
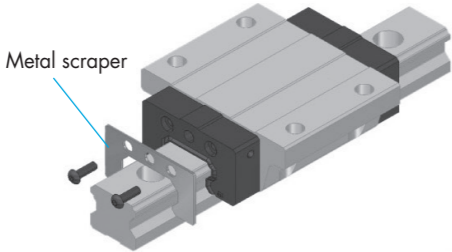
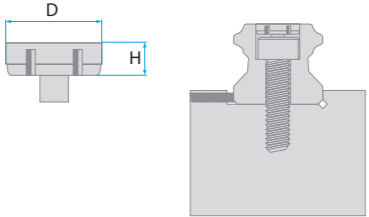
Item	Seal Positions	Applications
End seal		Miniature range <b>MLG</b> End seals
Inside seal		<b>Standard HLG</b> range End seal Side seal
Metal scraper		Optional scraper for the <b>HLG</b> range End seal Side seal Metal scraper MS. For scraping dirt and particles from the rail surface improving system life.
Rail cap		Rail cap to prevent dirt entering mounting holes (Supplied with each rail length order) <b>HLG</b> only

Metal Scraper (factory fitted)		
<b>HLGMS15</b>	Metal scraper set	comprising 2 x scraper seal + 4 x screws
<b>HLGMS20</b>	Metal scraper set	comprising 2 x scraper seal + 4 x screws
<b>HLGMS25</b>	Metal scraper set	comprising 2 x scraper seal + 4 x screws
<b>HLGMS30</b>	Metal scraper set	comprising 2 x scraper seal + 4 x screws
<b>HLGMS35</b>	Metal scraper set	comprising 2 x scraper seal + 4 x screws
<b>HLGMS45</b>	Metal scraper set	comprising 2 x scraper seal + 4 x screws
<b>HLGMS55</b>	Metal scraper set	comprising 2 x scraper seal + 4 x screws

## Installation Data

Rails should be fitted to a machined surface with a side datum as shown in Figure 4 .

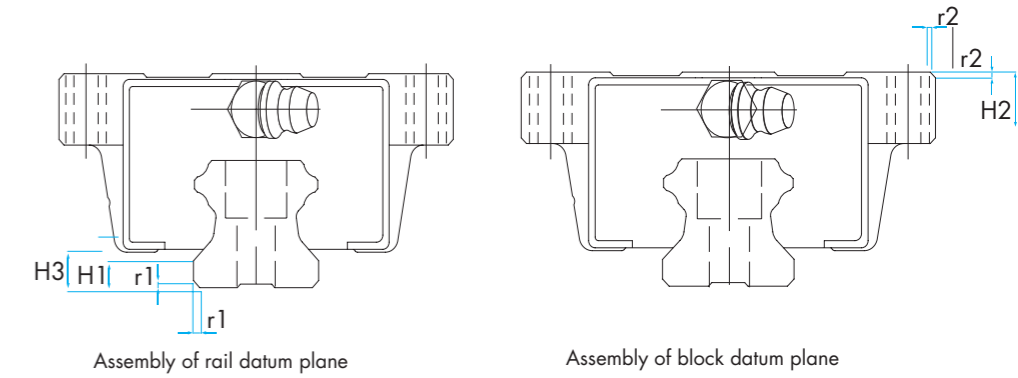
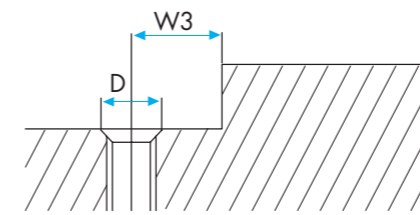

Figure 4. Dimensional tolerance between contact datum plane and mounting hole

Figure 5. Height of the raised section of mounting surface and radius of corner r

The depth of the datum will vary depending upon the size and type of block, please refer to the following table for datum dimensional details for both rails and blocks.

### HLG Series

Model No.	Radius of corner of the installation rail r1(max)	Radius of corner of the installation to block r2(max)	Height of raised spot of installation to rail H1	Height of raised section of the installation to block H2	H3
<b>15</b>	0.5	0.5	3	4	4.7
<b>20</b>	0.5	0.5	3.5	5	5
<b>25</b>	1	1	5	5	7
<b>30</b>	1	1	5	5	7.5
<b>35</b>	1	1	6	6	9
<b>45</b>	1	1	8	8	10
<b>55</b>	1.1	1.5	10	10	13

### HLGS Series

Model No.	Radius of corner of the installation rail r1(max)	Radius of corner of the installation to block r2(max)	Height of raised spot of installation to rail H1	Height of raised section of the installation to block H2	H3
<b>15</b>	0.5	0.1	2.5	4.0	4.5
<b>20</b>	0.5	1.0	4.0	5.0	6.0
<b>25</b>	1.0	1.0	5.0	5.0	7.0

### MLG Series, MLGB Series

Model No.	Radius of corner of the installation rail r1(max)	Radius of corner of the installation to block r2(max)	Height of raised spot of installation to rail H1	Height of raised section of the installation to block H2	H3
<b>5</b>	0.2	0.2	0.8	2	1
<b>7</b>	0.2	0.2	1.2	2.5	1.5
<b>9</b>	0.2	0.2	1.5	3	2
<b>12</b>	0.2	0.2	2.5	4	3
<b>15</b>	0.2	0.2	3	4.5	4
<b>20</b>	0.2	0.2	4	5	5

## Joining Rails

Rail lengths for **HLG** recirculating ball guides are supplied in lengths up to 4 metres in one piece, except miniature (please see page 10 for individual lengths). Butted rails will need to be ordered as a set.

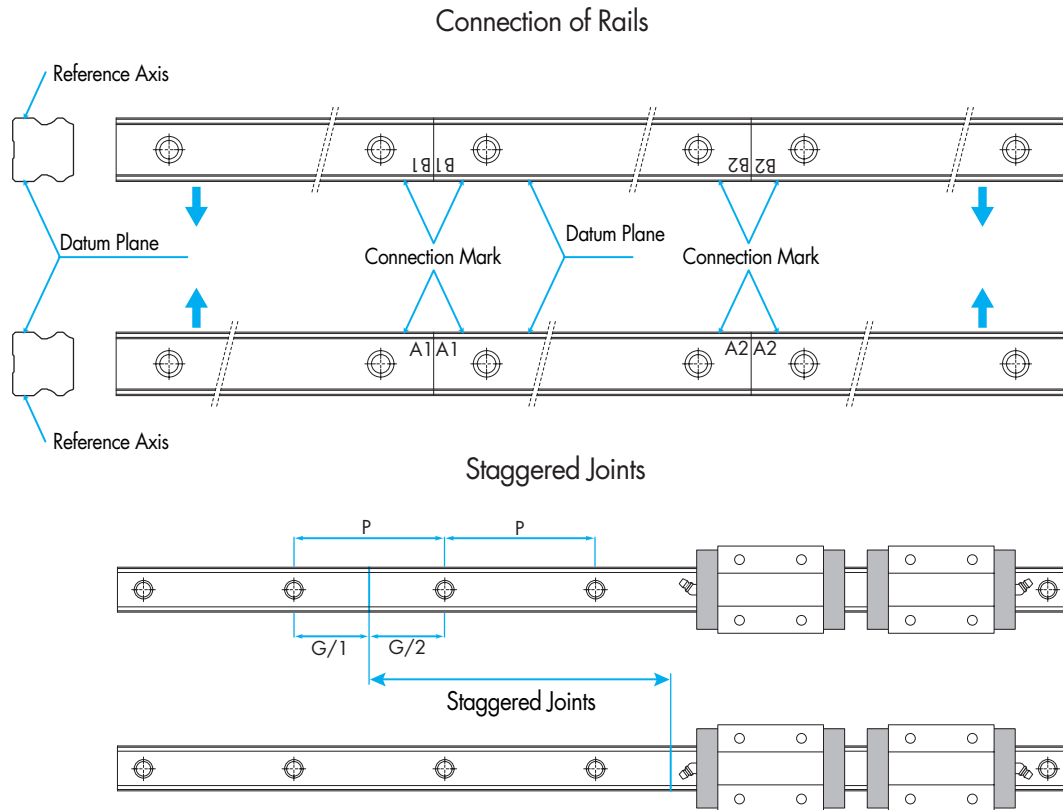

Figure 6. Joining Rails

Recommended bolt tightening torques depending on base material for **HLG** and **MLG** rails.

Bolt Size	Torque value (Unit : Nm)		
	Steel	Casting	Aluminium
<b>M3</b>	2	1.3	1
<b>M4</b>	4	2.7	2
<b>M5</b>	8.8	5.9	4.4
<b>M6</b>	13.7	9.2	6.8
<b>M8</b>	30	20	15
<b>M10</b>	68	45	33
<b>M12</b>	120	78	58
<b>M14</b>	157	105	78
<b>M16</b>	196	131	98
<b>M20</b>	382	255	191



## Block Installation

**HLG** blocks are supplied on a plastic guide rail to ensure the internal balls remain within the recirculating system in transit and also to make the assembly process simple.

It is important to align the end of the plastic guide rail to the rail and carefully slide the block on to the rail. Incorrect alignment could result in damage to the balls or even worse, loss of a number of balls from the recirculating system.

The block should move freely on the rail with no rough spots. Rough running is a sign that contamination has occurred or some balls have been accidentally released during the assembly process.

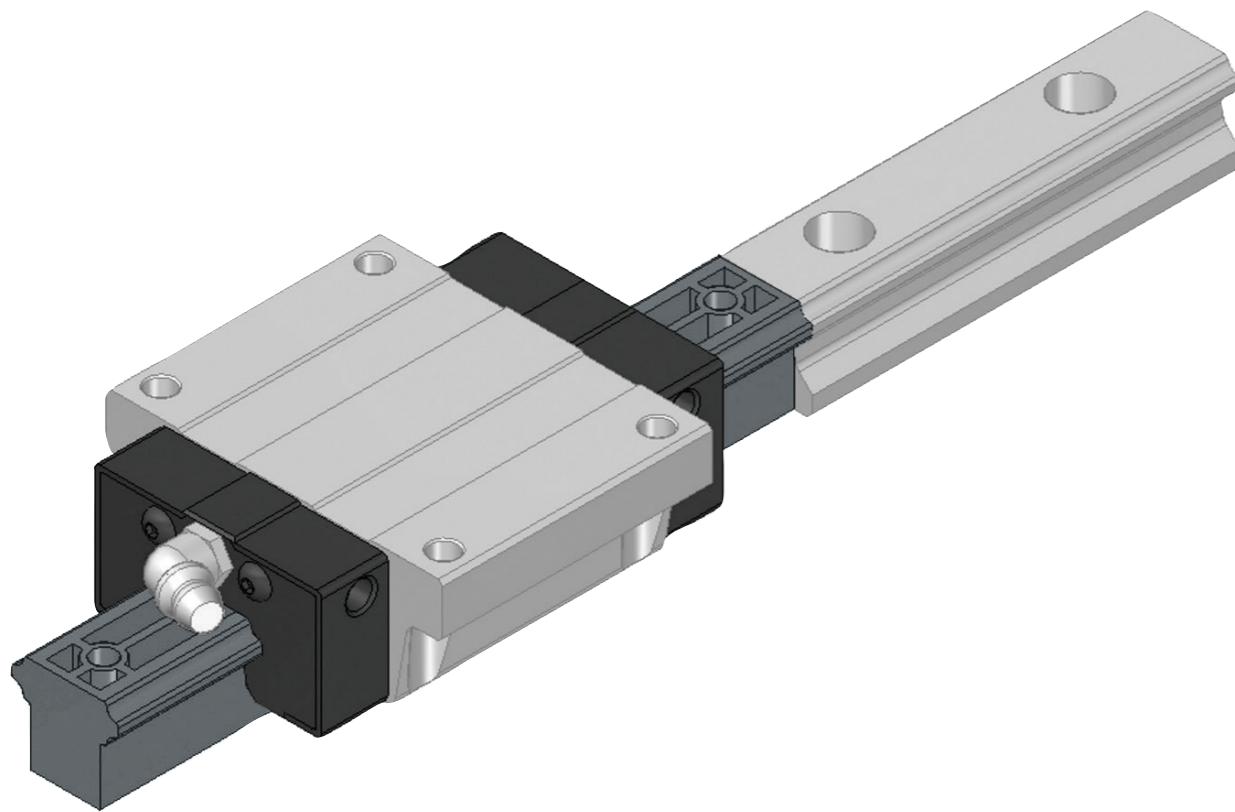

## HLG Ordering Detail

### Block

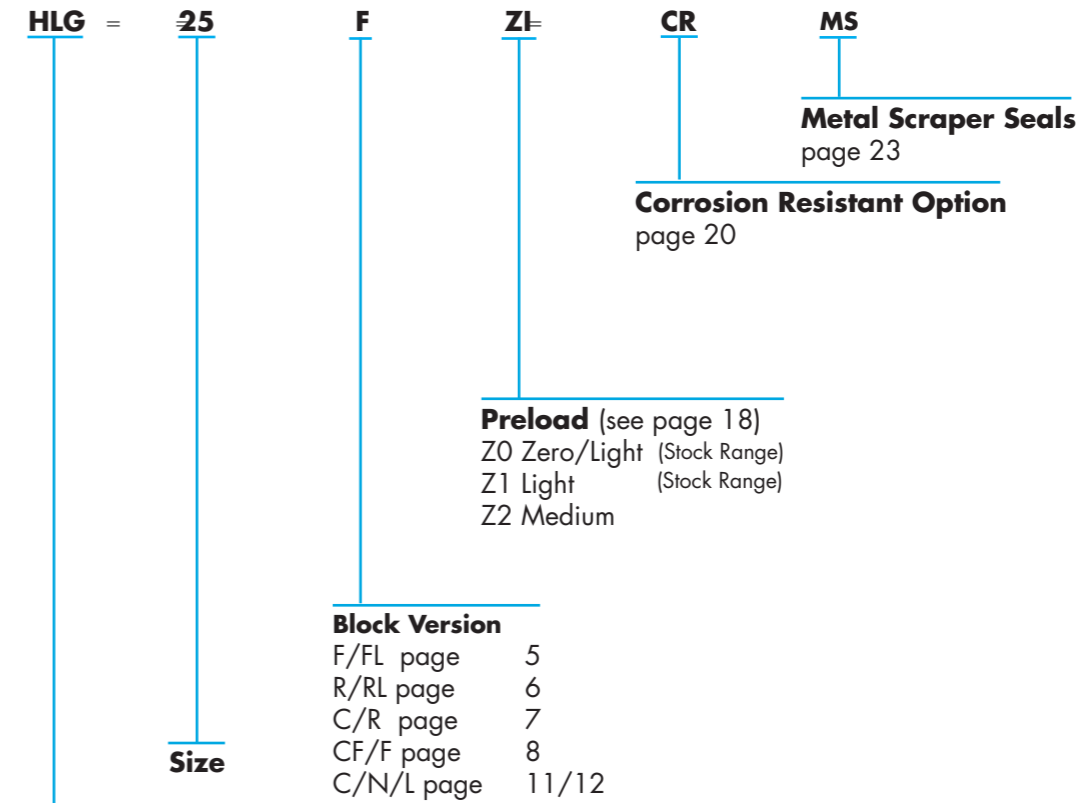

- HLG** Standard Series
- HLGS** Compact Series
- MLG** Miniature Standard
- MLGB** Miniature Wide

### Rail

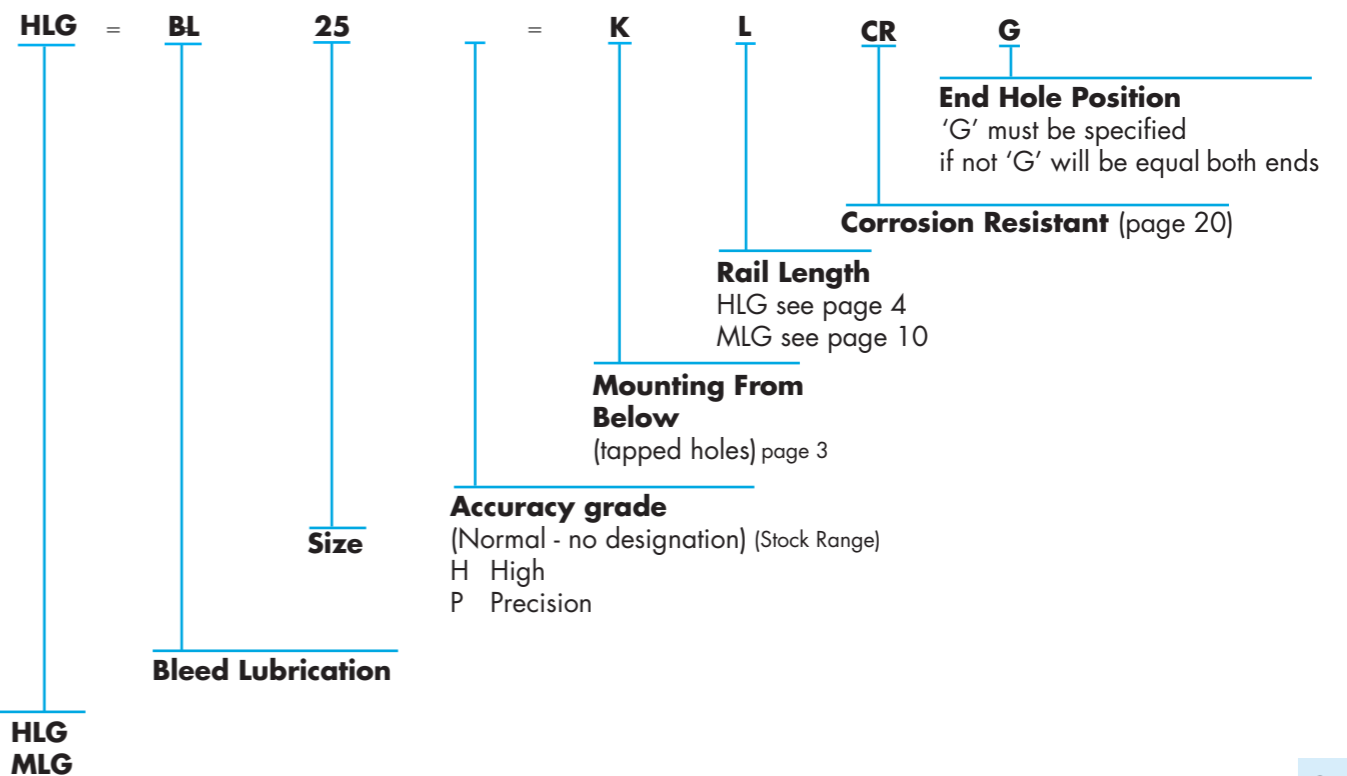





# HepcoMotion® Product Range



**GV3**  
Linear Guidance and  
Transmission System

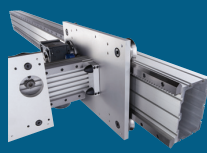

**HDS2**  
Heavy Duty  
Slide System

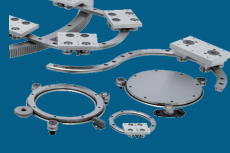

**PRT2**  
Precision Ring and  
Track System



**HDRT**  
Heavy Duty Ring Slides  
and Track System

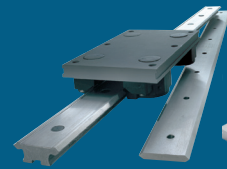

**SL2**  
Stainless Steel Based  
Slide System

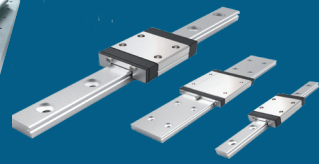

**HLG**  
Hepco Linear Guides

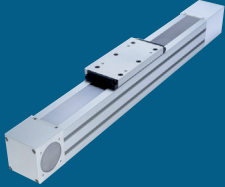

**SBD**  
Sealed Belt  
Drive



**MCS**  
Aluminium Frame  
and Machine  
Construction System

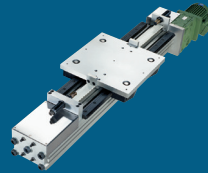

**HDLS**  
Heavy Duty Driven  
Linear System

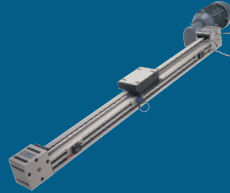

**DLS**  
Linear Transmission and  
Positioning System

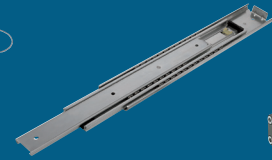

**HTS**  
Telescopic Ball Bearing  
Slides

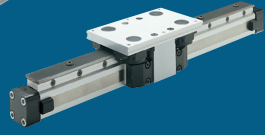

**HPS**  
Powerslide-2 Guided  
Rodless Cylinder

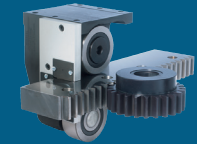

**MHD**  
Heavy Duty Track Roller  
Guidance System

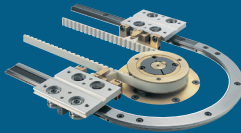

**DTS**  
Driven Track System



**BSP**  
Ballscrew Premier

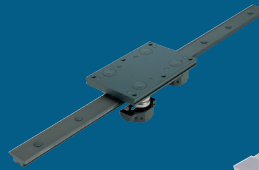

**Simple Select®**  
Vee Slide Linear  
Guidance Systems

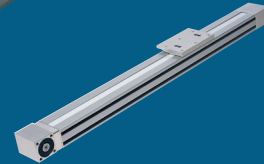

**PDU2**  
Profile Driven Unit

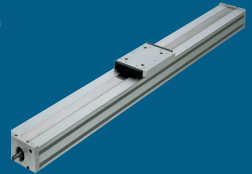

**PSD120**  
Profile Screw Driven Unit

For further information on HepcoMotion® products –  
please request our leaflet 'FPL'

## HepcoMotion®

[www.HepcoMotion.com](http://www.HepcoMotion.com)

### HepcoMotion® - Deutschland

Schwarzenbrucker Str. 1  
90537, Feucht, Deutschland  
Tel +49 (0) 9128 9271 0  
Fax: +49 (0) 9128 9271 50  
E-mail: [info.de@hepcotion.com](mailto:info.de@hepcotion.com)

### HepcoMotion® - Head Office

Lower Moor Business Park, Tiverton Way  
Tiverton, Devon, England EX16 6TG  
Tel: +44 (0)1884 257000  
Fax: +44 (0)1884 243500  
E-mail: [sales@hepcotion.com](mailto:sales@hepcotion.com)

### HepcoMotion® - España

Alt de Gironella, 36-38 bajos  
ES-08017, Barcelona, España  
Tel: +34 93 205 84 47  
Fax: +34 93 280 62 14  
E-mail: [info.es@hepcotion.com](mailto:info.es@hepcotion.com)

### HepcoMotion® - Benelux

Berkveld 14A  
NL-5709 AE Helmond, Nederland  
Tel +31 (0) 432 551290  
Fax: +31 (0) 432 528105  
E-mail: [info.nl@hepcotion.com](mailto:info.nl@hepcotion.com)

### HepcoMotion® - France

64 Chemin de la Chapelle, Saint Antoine  
ENNERY, 95300, France  
Tel: +33 01 34 64 30 44  
Fax: +33 01 34 64 3388  
E-mail: [info.fr@hepcotion.com](mailto:info.fr@hepcotion.com)

CATALOGUE No.HLG 01 UK © 2016 Hepco Slide Systems Ltd.

Reproduction in whole or part without prior authorisation from Hepco is prohibited. Although every effort has been made to ensure the accuracy of the information in this catalogue, Hepco cannot accept liability for any omissions or errors. Hepco reserves the right to make alterations to the product resulting from technical developments.

Many Hepco products are protected by: Patents, Copyright, Design Right or Registered Design. Infringement is strictly prohibited and may be challenged in law. The Customer's attention is drawn to the following clause in Hepco's conditions of sale:

'It shall be the Customer's sole responsibility to ensure that goods supplied by Hepco will be suitable or fit for any particular application or purpose of the Customer, whether or not such application or purpose is known to Hepco. The Customer will be solely responsible for any errors in, or omissions from, any specifications or information the Customer provides. Hepco will not be obliged to verify whether any such specifications or information are correct or sufficient for any application or purpose.'

Hepco's full conditions of sale are available on request and will apply to all quotations and contracts for the supply of items detailed in this catalogue.

HepcoMotion is the trading name of Hepco Slide Systems Ltd.