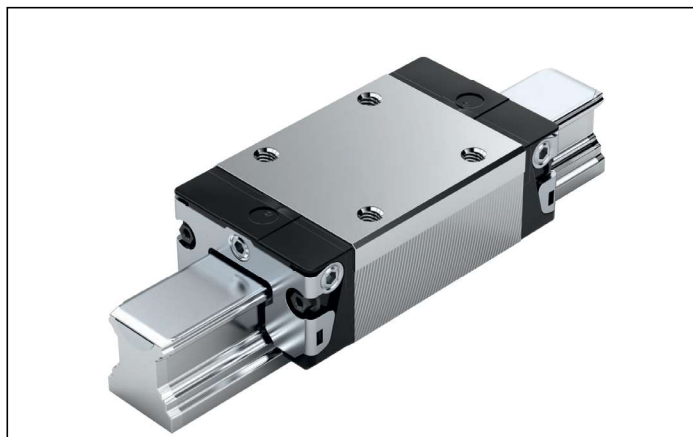

SNS – slimline, normal, standard height R1622 ... 2.

**Dynamic characteristics**Travel speed: $v_{\max} = 5 \text{ m/s}$ Acceleration: $a_{\max} = 500 \text{ m/s}^2$ (If $F_{\text{comb}} > 2.8 \cdot F_{\text{pr}}$: $a_{\max} = 50 \text{ m/s}^2$)**Note on lubrication**

▶ Pre-lubricated

Note

For all SNS/SNO ball guide rails.

Options and part numbers

Size	Ball runner block with size	Preload class				Accuracy class				Seal with ball runner blocks					
		C0	C1	C2	C3	N	H	P	XP	without ball chain			with ball chain		
										SS	LS ¹⁾	DS	SS	LS ¹⁾	DS
15	R1622 1	9				4	3	–	–	20	21	–	22	23	–
			1			4	3	2	8	20	21	–	22	23	–
				2		–	3	2	8	20	21	–	22	23	–
					3	–	–	–	8	20	21	–	22	23	–
20	R1622 8	9				4	3	–	–	20	21	–	22	23	–
			1			4	3	2	8	20	21	2Z	22	23	2Y
				2		–	3	2	8	20	21	2Z	22	23	2Y
					3	–	–	–	8	20	21	2Z	22	23	2Y
25	R1622 2	9				4	3	–	–	20	21	–	22	23	–
			1			4	3	2	8	20	21	2Z	22	23	2Y
				2		–	3	2	8	20	21	2Z	22	23	2Y
					3	–	–	–	8	20	21	2Z	22	23	2Y
30	R1622 7	9				4	3	–	–	20	21	–	22	23	–
			1			4	3	2	8	20	21	2Z	22	23	2Y
				2		–	3	2	8	20	21	2Z	22	23	2Y
					3	–	–	–	8	20	21	2Z	22	23	2Y
35	R1622 3	9				4	3	–	–	20	21	–	22	23	–
			1			4	3	2	8	20	21	2Z	22	23	2Y
				2		–	3	2	8	20	21	2Z	22	23	2Y
					3	–	–	–	8	20	21	2Z	22	23	2Y
45	R1622 4	9				4	3	–	–	20	–	–	22	–	–
			1			4	3	2	8	20	–	2Z	22	–	2Y
				2		–	3	2	8	20	–	2Z	22	–	2Y
					3	–	–	–	8	20	–	2Z	22	–	2Y
e.g.	R1622 7		1				3			20					

1) With accuracy classes N and H and XP in preload class C1 only.

Order example

Options:

- ▶ SNS ball runner blocks
- ▶ Size 30
- ▶ Preload class C1
- ▶ Accuracy class H
- ▶ With standard seal, without ball chain

Part number:

R1622 713 20

Preload classes

C0 = Without preload (clearance)
 C1 = Moderate preload
 C2 = Average preload
 C3 = High preload

Seals

SS = standard seal
 LS = low-friction seal
 DS = double-lipped seal

Key

Gray digits
 = No preferred variant/combination
 (Some delivery times may be longer)

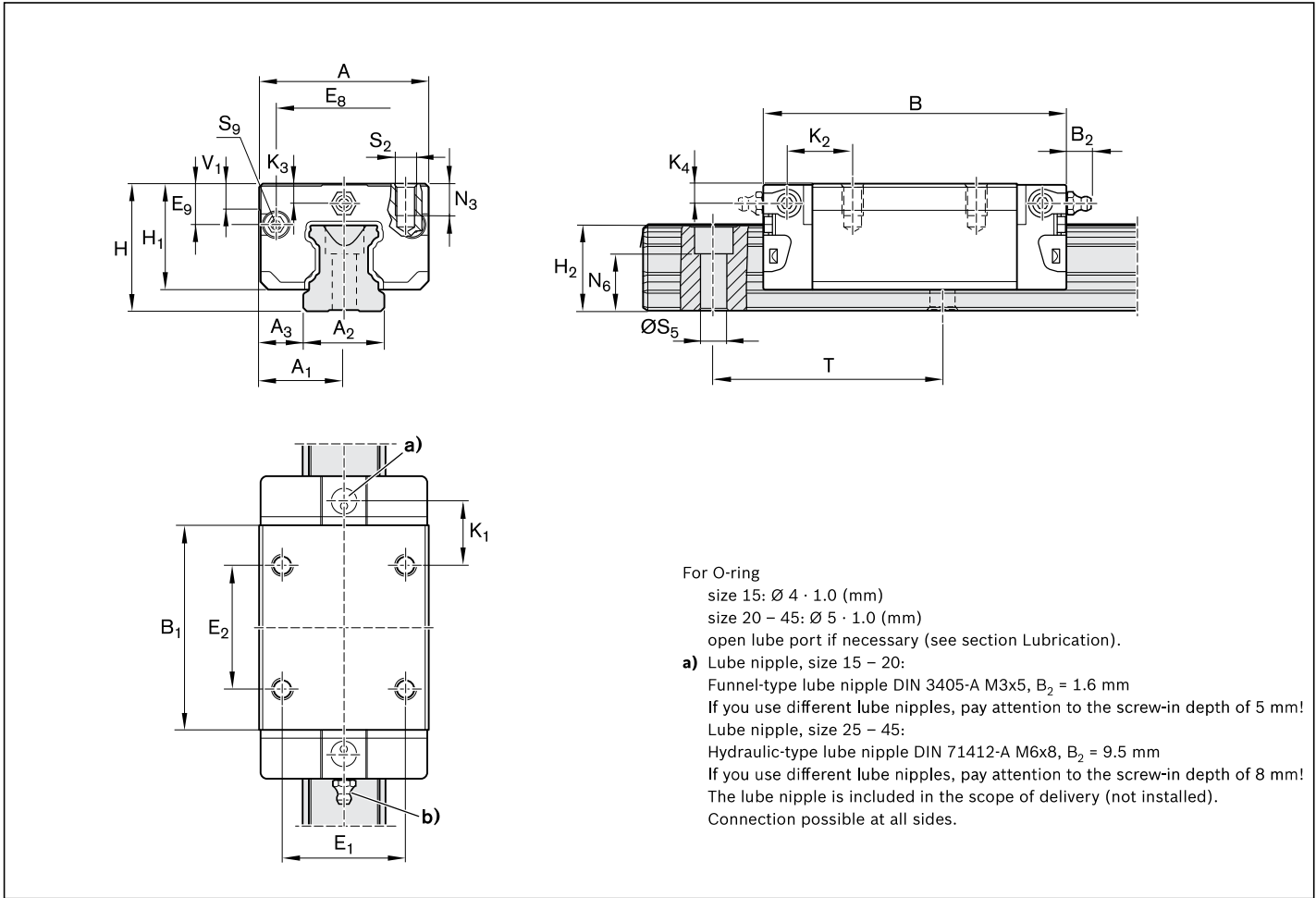

For O-ring
 size 15: Ø 4 · 1.0 (mm)
 size 20 – 45: Ø 5 · 1.0 (mm)
 open lube port if necessary (see section Lubrication).
a) Lube nipple, size 15 – 20:
 Funnel-type lube nipple DIN 3405-A M3x5, B₂ = 1.6 mm
 If you use different lube nipples, pay attention to the screw-in depth of 5 mm!
 Lube nipple, size 25 – 45:
 Hydraulic-type lube nipple DIN 71412-A M6x8, B₂ = 9.5 mm
 If you use different lube nipples, pay attention to the screw-in depth of 8 mm!
 The lube nipple is included in the scope of delivery (not installed).
 Connection possible at all sides.

Size	Dimensions (mm)																	
	A	A ₁	A ₂	A ₃	B ^{+0.5}	B ₁	E ₁	E ₂	E ₈	E ₉	H	H ₁	H ₂ ¹⁾	H ₂ ²⁾	K ₁	K ₂	K ₃	K ₄
15	34	17	15	9.5	58.2	39.2	26	26	24.55	6.70	24	19.90	16.30	16.20	10.00	11.60	3.20	3.20
20	44	22	20	12.0	75.0	49.6	32	36	32.50	7.30	30	25.35	20.75	20.55	13.80	13.80	3.35	3.35
25	48	24	23	12.5	86.2	57.8	35	35	38.30	11.50	36	29.90	24.45	24.25	17.45	18.60	5.50	5.50
30	60	30	28	16.0	97.7	67.4	40	40	48.40	14.60	42	35.35	28.55	28.35	20.00	21.70	6.05	6.05
35	70	35	34	18.0	110.5	77.0	50	50	58.00	17.35	48	40.40	32.15	31.85	20.50	22.00	6.90	6.90
45	86	43	45	20.5	137.6	97.0	60	60	69.80	20.90	60	50.30	40.15	39.85	27.30	29.30	8.20	8.20

Size	Dimensions (mm)								Weight (kg)	Load capacities ³⁾ (N)		Load moments ³⁾ (Nm)			
	N ₃	N ₆ ^{±0.5}	S ₂	S ₅	S ₉	T	V ₁	m		C	C ₀	M _t	M _{t0}	M _L	M _{L0}
15	6.0	10.3	M4	4.5	M2.5x3.5	60	5.0	0.15	9 860	12 700	95	120	68	87	
20	7.5	13.2	M5	6.0	M3x5	60	6.0	0.35	23 400	29 800	300	380	200	260	
25	9.0	15.2	M6	7.0	M3x5	60	7.5	0.50	28 600	35 900	410	510	290	360	
30	12.0	17.0	M8	9.0	M3x5	80	7.0	0.85	36 500	48 100	630	830	440	580	
35	13.0	20.5	M8	9.0	M3x5	80	8.0	1.25	51 800	80 900	1 110	1 740	720	1 130	
45	18.0	23.5	M10	14.0	M4x7	105	10.0	2.40	86 400	132 000	2 330	3 560	1 540	2 350	

- 1) Dimension H₂ with cover strip
 - 2) Dimension H₂ without cover strip
 - 3) Load capacities and load moments for ball runner blocks **without** ball chain. Load capacities and load moments for ball runner blocks **with** ball chain. 12
- Determination of the dynamic load capacities and load moments is based on a 100,000 m travel life according to DIN ISO14728-1. Often only 50,000 m are actually stipulated. For comparison: Multiply values **C**, **M_t** and **M_L** by 1.26 according to the table.

SNS – slimline normal standard height, R1622 ...1.

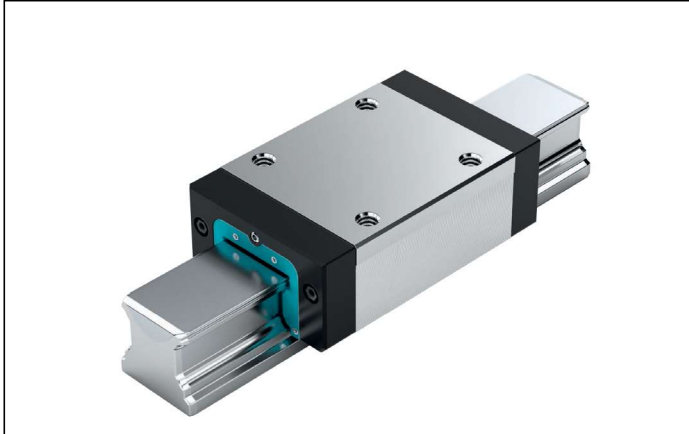

Dynamic characteristics

Travel speed: $v_{\max} = 3 \text{ m/s}$
 Acceleration: $a_{\max} = 250 \text{ m/s}^2$
 (If $F_{\text{comb}} > 2.8 \cdot F_{\text{pr}}$: $a_{\max} = 50 \text{ m/s}^2$)

Note on lubrication

► Not pre-lubricated

Note

Can be used on all ball guide rails SNS.

Options and part numbers

Size	Ball runner block with size	Preload class				Accuracy class			Seal with ball runner blocks without ball chain	SS
		C0	C1	C2	C3	N	H	P		
55	R1622 5	9				4	3	–	10	
			1			4	3	2	10	
				2		–	3	2	10	
					3	–	–	2	10	
65	R1622 6	9				4	3	–	10	
			1			4	3	2	10	
				2		–	3	2	10	
					3	–	–	2	10	
e.g.	R1622 5		1			3		10		

Order example

Options:

- SNS ball runner blocks
- Size 55
- Preload class C1
- Accuracy class H
- With standard seal, without ball chain

Part number:

R1622 513 10

Preload classes

C0 = Without preload (clearance)
 C1 = Moderate preload
 C2 = Average preload
 C3 = High preload

Seals

SS = standard seal

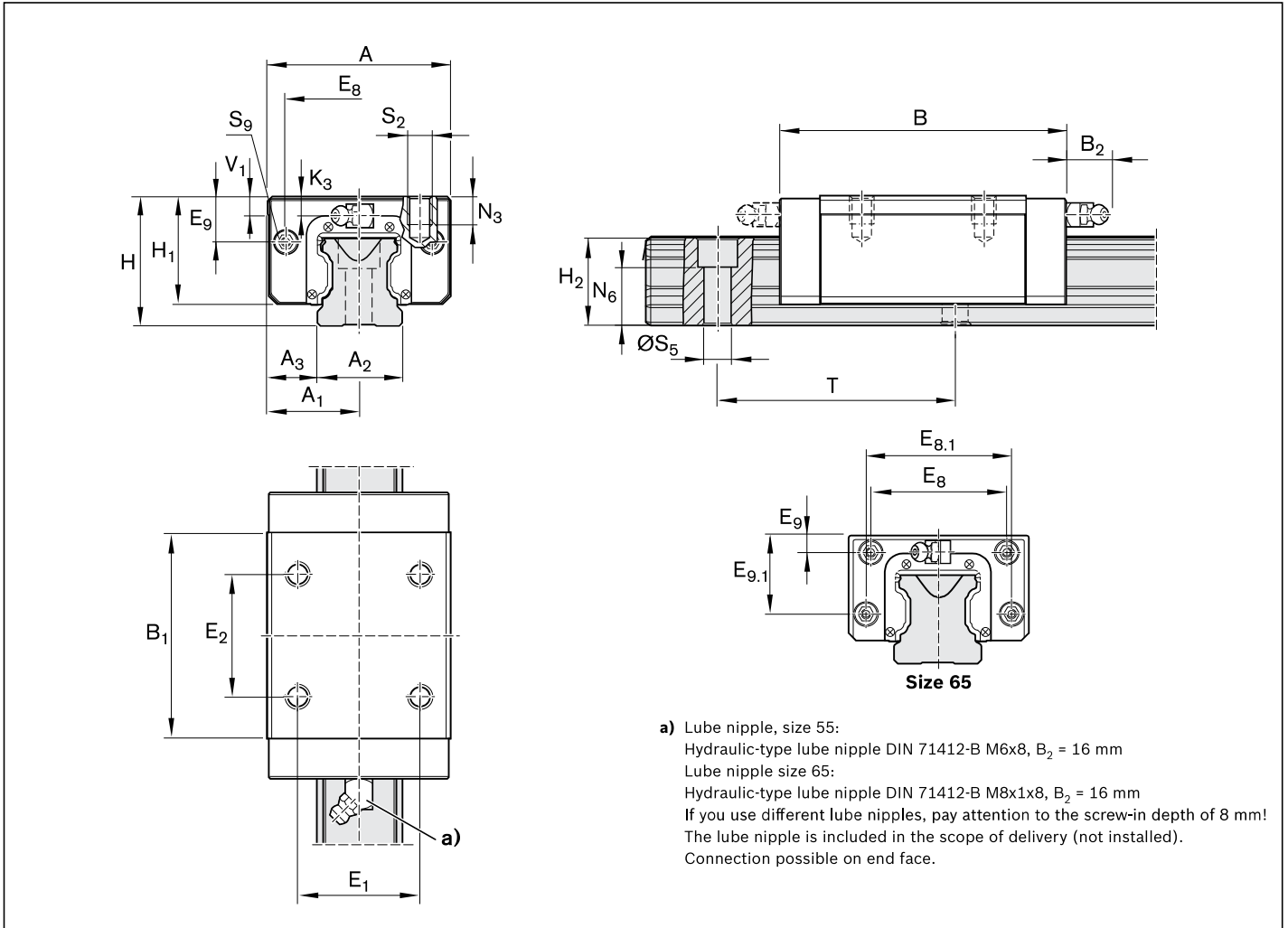

Size	Dimensions (mm)															
	A	A ₁	A ₂	A ₃	B ^{+0.5}	B ₁	E ₁	E ₂	E ₈	E _{8.1}	E ₉	E _{9.1}	H	H ₁	H ₂ ¹⁾	H ₂ ²⁾
55	100	50	53	23.5	159	115.5	75	75	80	-	22.3	-	70	57	48.15	47.85
65	126	63	63	31.5	188	139.6	76	70	76	100	11.0	53.5	90	76	60.15	59.85

Size	Dimensions (mm)									Weight (kg)	Load capacities ³⁾ (N)		Load moments ³⁾ (Nm)			
	K ₃	N ₃	N ₆ ^{+0.5}	S ₂	S ₅	S ₉	T	V ₁	m		C	C ₀	M _t	M _{t0}	M _L	M _{L0}
55	9	19	29.0	M12	16	M5x8	120	12	3.80	109 000	174 000	3 480	5 550	2 320	3 690	
65	16	21	38.5	M16	18	M4x7	150	15	6.90	172 000	280 000	6 810	11 100	4 560	7 400	

- 1) Dimension H₂ with cover strip
- 2) Dimension H₂ without cover strip
- 3) Load capacities and load moments for ball runner blocks **without** ball chain.
Determination of the dynamic load capacities and load moments is based on a 100,000 m travel life according to DIN ISO14728-1. Often only 50,000 m are actually stipulated. For comparison: Multiply values **C**, **M_t** and **M_L** by 1.26 according to the table.