

FNN – Flange, normal, low profile R1693 ... 1.



Dynamic characteristics

Travel speed: $v_{\max} = 3 \text{ m/s}$

Acceleration: $a_{\max} = 250 \text{ m/s}^2$

(If $F_{\text{comb}} > 2.8 \cdot F_{\text{pr}}$: $a_{\max} = 50 \text{ m/s}^2$)

Note on lubrication

- ▶ Not pre-lubricated

Note

For all SNS/SNO ball guide rails.

Options and part numbers

Size	Ball runner block with size	Preload class		Accuracy class		Seal with ball runner blocks without ball chain	
		C0	C1	N	H	SS	LS
20	R1693 8	9	1	4	3	10	11
25 ¹⁾	R1693 2	9	1	4	3	10	11
e.g.	R1693 8		1		3	10	

1) BSHP ball runner block

Order example

Options:

- ▶ FNN ball runner block
- ▶ Size 20
- ▶ Preload class C1
- ▶ Accuracy class H
- ▶ With standard seal, without ball chain

Part number:

R1693 813 10

Preload classes

C0 = Without preload (clearance)
C1 = Moderate preload

Seals

SS = standard seal
LS = low-friction seal

Key

Gray digits

= No preferred variant/combination
(Some delivery times may be longer)

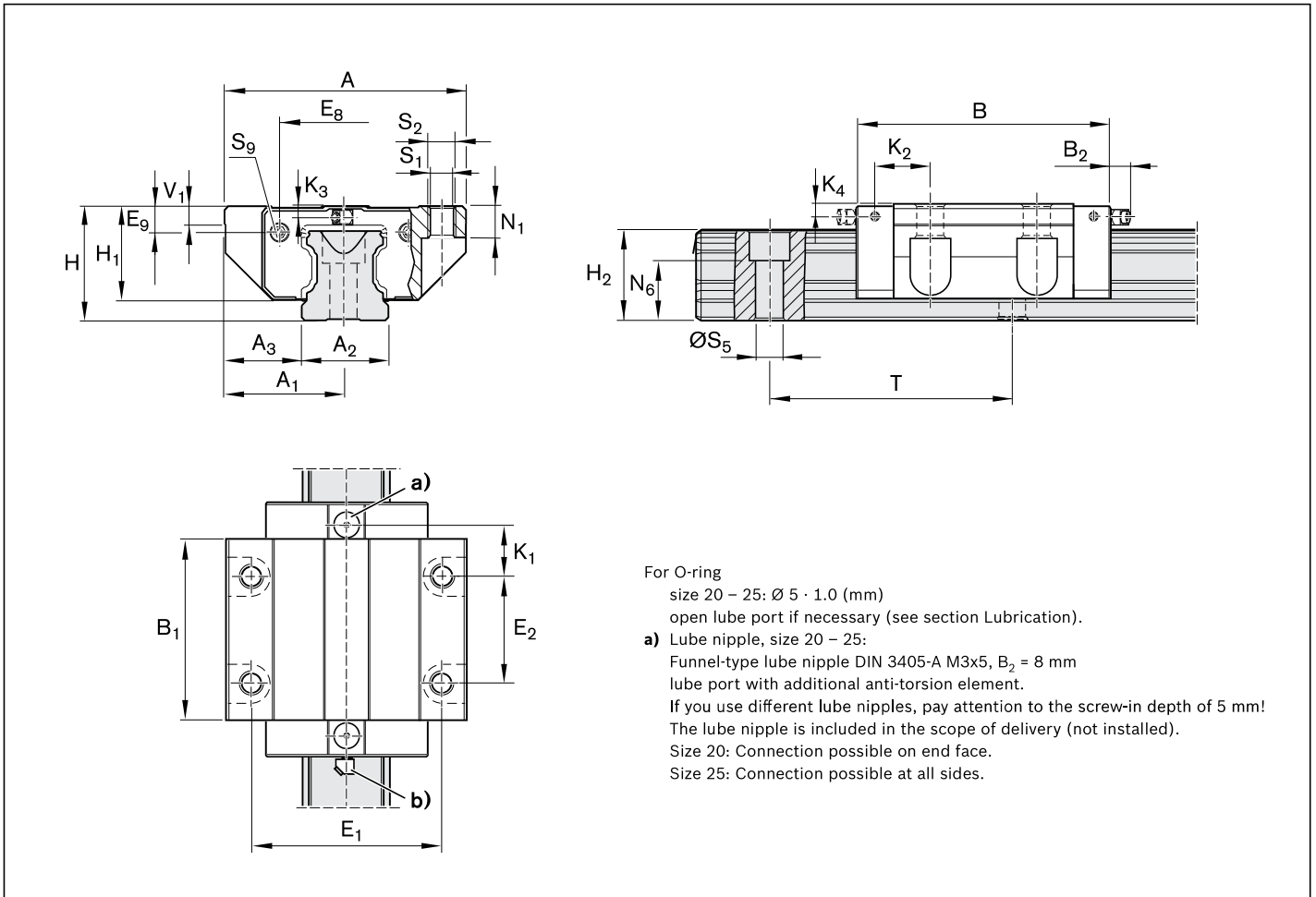

Size	Dimensions (mm)																	
	A	A ₁	A ₂	A ₃	B ^{+0.5}	B ₁	E ₁	E ₂	E ₈	E ₉	H	H ₁	H ₂ ¹⁾	H ₂ ²⁾	K ₁	K ₂	K ₃	K ₄
20	59	29.5	20	19.5	72.5	49.6	49	32	30.5	5.6	28	23.0	20.75	20.55	13.0	-	3.6	-
25	73	36.5	23	25.0	81.0	57.8	60	35	38.3	8.5	33	26.5	24.45	24.25	16.6	17.0	4.1	4.1

Size	Dimensions (mm)									Weight (kg)	Load capacities ³⁾ (N)		Load moments ³⁾ (Nm)			
	N ₁	N ₆ ^{+0.5}	S ₁	S ₂	S ₅	S ₉	T	V ₁	m		C	C ₀	M _t	M _{t0}	M _L	M _{L0}
20	7.7	13.2	5.3	M6	6.0	M3x5	60	6.0	0.40	14 500	24 400	190	310	100	165	
25	9.3	15.2	6.7	M8	7.0	M3x5	60	7.5	0.60	28 600	35 900	410	510	290	360	

- 1) Dimension H₂ with cover strip
 - 2) Dimension H₂ without cover strip
 - 3) Load capacities and load moments for ball runner blocks **without** ball chain.
- Determination of the dynamic load capacities and load moments is based on a 100,000 m travel life according to DIN ISO14728-1. Often only 50,000 m are actually stipulated. For comparison: Multiply values **C**, **M_t** and **M_L** by 1.26 according to the table.