

TUFF SERIES HEAVY DUTY UNITS

ALWAYS TUFF SERIES Heavy Duty units are built to provide a long working life and to withstand harsh conditions.

They have a solid machined body with chrome steel bearings and incorporate both dust seal and dirt exit hole (except No. 0519).

They provide a higher load capacity than standard units.

Solid steel body for attachment purposes, but not shock loading. Body chemical black finish for types 13 and 16.

All units are machined using CNC machines from one piece of steel, therefore flanges and threads are integral.

ALSO AVAILABLE

All patterns (i.e.: 21,22,23 and 24) of refos 0519, 3019 and 1019 are available with a nylon main ball (Type 14) ideal for light load and reduced marking

TUFF HEAVY DUTY 21

Features: Plain solid machined body.

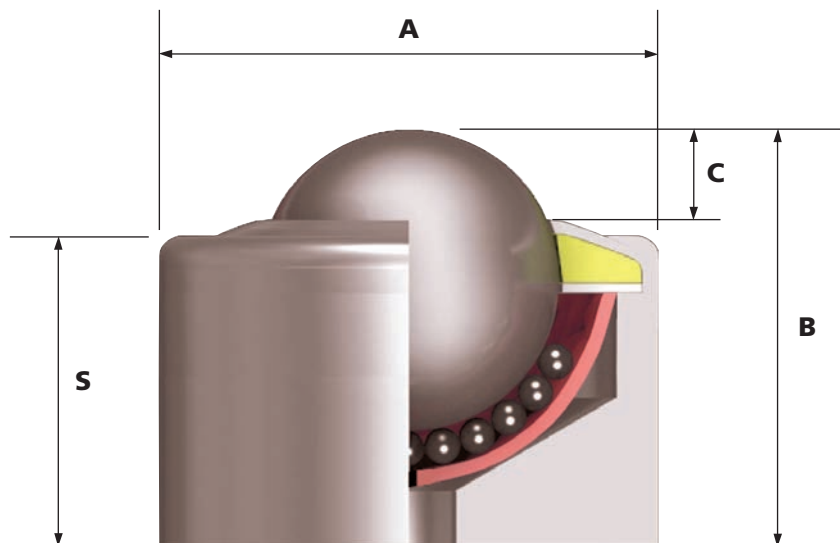

TUFF HEAVY DUTY 22

Features: Flange fixing either by using rivets or screws.

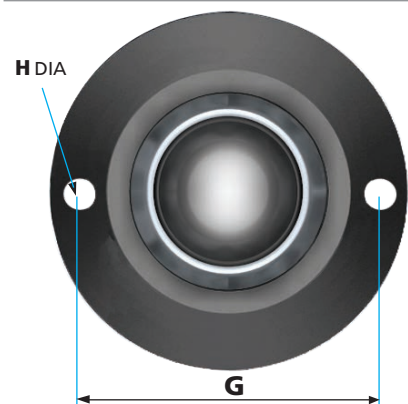
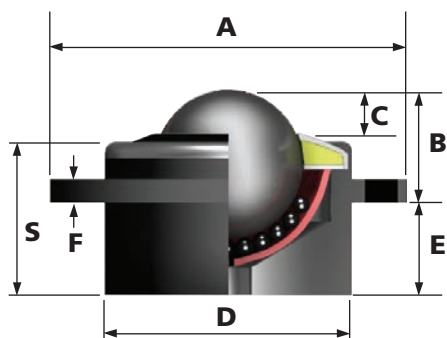

TUFF HEAVY DUTY 23

Features: Bolt, drilled hole fixing. Maximum tightening torques range from 10Nm for M6 to 20Nm for M12.

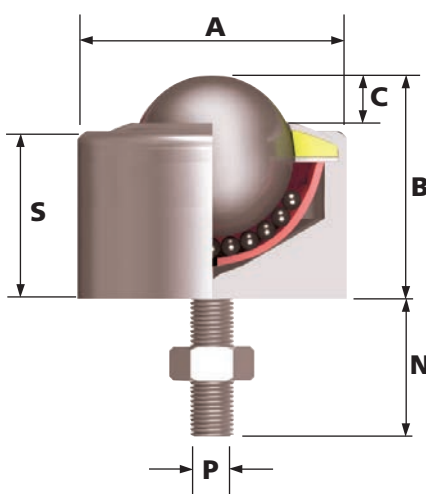

TUFF HEAVY DUTY 24

Features: Bottom flange fixing either by using rivets or screws. Drilled hole fixing.

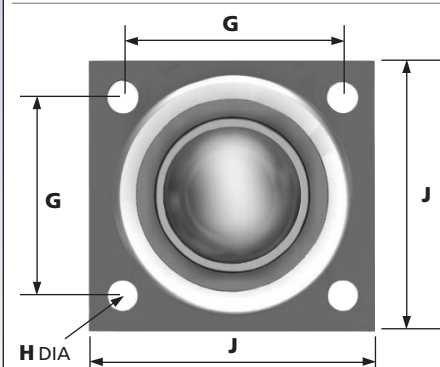
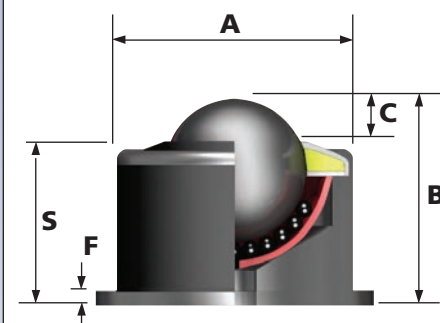

REF No.	BALL SIZE (mm)	WEIGHT (KGS)	DIMENSIONS (mm)											DYNAMIC LOAD CAPACITY (kg)	
			A	B	C	D	E	F	G	H	J	N	P	S	TYPE 13 Carbon Steel Bearings, Zinc Plated Pressings

0519-21	12.7	0.036	20	20	2	-	-	-	-	-	-	-	-	17	25	25	
0519-22		0.051	32	12		20	8	4	26 ±0.2	3.5	-	-	-	-			17
0519-23		0.042	20	20		-	-	-	-	-	-	28	M6	17			
0519-24		0.096	20	25		-	-	6	24 ±0.2	6.5	35	-	-	22			

3019-21	19	0.120	30	30	4	-	-	-	-	-	-	-	-	26	50	50
3019-22		0.168	50	14		30	16	5	40 ±0.2	5	-	-	-	26		
3019-23		0.124	30	30		-	-	-	-	-	-	25	M8	26		
3019-24		0.220	30	35		-	-	6	31 ±0.2	6.5	44.5	-	-	31		

1019-21	25.4	0.177	35	35	7	-	-	-	-	-	-	-	-	28	125	125
1019-22		0.282	60	20		40	15	5	49 ±0.2	5	-	-	-	28		
1019-23		0.190	35	35		-	-	-	-	-	-	40	M8	28		
1019-24		0.294	35	40		-	-	6	35 ±0.2	7	50	-	-	33		

1029-21	31.7	0.486	50	45	8	-	-	-	-	-	-	-	-	37	250	250
1029-22		0.584	75	24		50	21	5	62.5 ±0.2	5	-	-	-	37		
1029-23		0.500	50	45		-	-	-	-	-	-	40	M10	37		
1029-24		0.740	50	50		-	-	8	49 ±0.2	7	63.45	-	-	42		

2019-21	39.7	0.850	60	55	9	-	-	-	-	-	-	-	-	46	500	250
2019-22		0.960	84	27		60	28	5	72 ±0.2	6	-	-	-	46		
2019-23		0.900	60	55		-	-	-	-	-	-	50	M12	46		
2019-24		1.350	60	60		-	-	10	60 ±0.2	7	80	-	-	51		

To order, specify REF N° and TYPE, i.e. 0519-21-13.

General Tolerance unless stated ±0.3mm